

**Volume-XIII**

# STRABAG

## JV of STRABAG Infrastructure & Safety Solutions GmbH and STRABAG AG

**Mumbai Trans Harbour Link Project, Package-4**

**Design, Supply, Installation, Testing and Commissioning of Intelligent Transport System (ITS), Toll Management System, Electrical works, Highway and Bridge streetlighting system, Construction of Toll Plazas and Administrative Buildings including Command Control Centre**

## Bid Documents





## INDEX

S no	Particulars	Page No.
01.00	Form CHK	1
02.00	Letter of Technical Bid	4
03.00	Tender Fee (Payment Details)	7
04.00	Bid Security	9
05.00	Form ACK	14
06.00	Form ELI-1 Applicant Information Form (JV)	
	Attachments to Form ELI-1	17
	06.01 Letter of Intent to enter in JV Agreement	20
07.00	Form ELI - 2: Bidder's Party Information (STRABAG Infrastructure & Safety Solutions GmbH)	23
	Attachments to Form ELI-2	
	07.01 Power of Attorney	25
	07.02 Incorporation Certificate / MOA & AOA / Board Resolution	32
	07.03 Organizational Chart	45
	07.04 List of Board of Directors	47
	07.05 Share Holding Pattern	49
08.00	Form ELI - 2: Bidder's Party Information (STRABAG AG)	51
	Attachments to Form ELI-2	
	08.01 Power of Attorney	53
	08.02 Incorporation Certificate / MOA & AOA / Board Resolution	60
	08.03 Organizational Chart	139
	08.04 List of Board of Directors	141
	08.05 Share Holding Pattern	143
09.00	Form ELI - 2: Bidder's Party Information (EKFON India Private Limited)	145
	Attachments to Form ELI-2	
	09.01 Incorporation Certificate / MOA & AOA	147
	09.02 Power of Attorney	236
	09.02.01 Board Resolution	239
	09.03 Organizational Chart	241
	09.04 List of Board of Directors	243
	09.05 Share Holding Pattern	245
	09.06 Letter of undertaking to be a specialist Subcontractor	247



## INDEX

S no	Particulars	Page No.
10.00	Form ELI - 2: Bidder's Party Information (Gajra Infra Pvt Ltd.)	249
	Attachments to Form ELI-2	
10.01	Incorporation Certificate / MOA & AOA	251
10.02	Organizational Chart	258
10.03	List of Board of Directors	260
10.04	Share Holding Pattern	262
10.05	Letter of undertaking to be a specialist Subcontractor	264
11.00	Form ELI - 2: Bidder's Party Information (Ascent Engineers & Infrastructure India Pvt Ltd)	266
	Attachments to Form ELI-2	
11.01	Incorporation Certificate / MOA & AOA	268
11.02	Power of Attorney	292
11.03	Organizational Chart	297
11.04	List of Board of Directors	299
11.05	Share Holding Pattern	301
11.06	Letter of undertaking to be a specialist Subcontractor	303
12.00	Form ELI - 2: Bidder's Party Information (N.A. Construction Pvt Ltd)	305
	Attachments to Form ELI-2	
12.01	Incorporation Certificate / MOA & AOA	307
12.02	Power of Attorney	341
12.03	Organizational Chart	348
12.04	List of Board of Directors	350
12.05	Share Holding Pattern	352
12.06	Letter of undertaking to be a specialist Subcontractor	354
13.00	Form CON: Historical Contract Non-Performance (STRABAG Infrastructure & Safety Solutions GmbH)	356
14.00	Form CON: Historical Contract Non-Performance (STRABAG AG)	360
15.00	Form FIN - 1: Financial Situation (STRABAG Infrastructure & Safety Solutions GmbH)	365
	Attachments to Form FIN - 1	
15.01	Certificate from Statutory Auditor	369
15.02	Financial statements for the 5 years (2020-2016)	373
	15.02.01 Financial Statement FY - 2020	374





## INDEX

S no	Particulars		Page No.
	15.02.02	Financial Statement FY - 2019	417
	15.02.03	Financial Statement FY - 2018	459
	15.02.04	Financial Statement FY - 2017	510
	15.02.05	Financial Statement FY - 2016	562
16.00	Form FIN - 1: Financial Situation (STRABAG AG)		617
	Attachments to Form FIN - 1		
16.01	Certificate from Statutory Auditor		621
16.02	Financial statements for the 5 years (2020-2016)		625
	16.02.01	Financial Statement FY - 2020	626
	16.02.02	Financial Statement FY - 2019	747
	16.02.03	Financial Statement FY - 2018	891
	16.02.04	Financial Statement FY - 2017	1038
	16.02.05	Financial Statement FY - 2016	1205
17.00	Form FIN - 2: Average Annual Turnover (STRABAG Infrastructure & Safety Solutions GmbH)		1370
	Attachments to Form FIN - 2		
17.01	Certificate from Statutory Auditor		1372
17.02	Balance Sheet & P&L for the 10 years (2020-2011)		1376
	17.02.01	Financial Statement FY - 2020	1377
	17.02.02	Financial Statement FY - 2019	1380
	17.02.03	Financial Statement FY - 2018	1383
	17.02.04	Financial Statement FY - 2017	1386
	17.02.05	Financial Statement FY - 2016	1389
	17.02.06	Financial Statement FY - 2015	1392
	17.02.07	Financial Statement FY - 2014	1395
	17.02.08	Financial Statement FY - 2013	1398
	17.02.09	Financial Statement FY - 2012	1401
	17.02.10	Financial Statement FY - 2011	1405
17.00	Form FIN - 2: Average Annual Turnover (STRABAG AG)		1431
	Attachments to Form FIN - 2		
18.01	Certificate from Statutory Auditor		1433
18.02	Balance Sheet & P&L for the 10 years (2020-2011)		1437





## INDEX

S no	Particulars		Page No.
	18.02.01	Financial Statement FY - 2020	1438
	18.02.02	Financial Statement FY - 2019	1444
	18.02.03	Financial Statement FY - 2018	1450
	18.02.04	Financial Statement FY - 2017	1456
	18.02.05	Financial Statement FY - 2016	1462
	18.02.06	Financial Statement FY - 2015	1468
	18.02.07	Financial Statement FY - 2014	1474
	18.02.08	Financial Statement FY - 2013	1480
	18.02.09	Financial Statement FY - 2012	1486
	18.02.10	Financial Statement FY - 2011	1492
19.00	Form FIR - 1: Financial Resources (STRABAG Infrastructure & Safety Solutions GmbH)		1498
20.00	Form FIR - 1: Financial Resources (STRABAG AG)		1503
21.00	Form FIR - 2: Current Contract Commitments (STRABAG Infrastructure & Safety Solutions GmbH)		1508
22.00	Form FIR - 2: Current Contract Commitments (STRABAG AG)		1511
23.00	Form FIR - 2: Current Contract Commitments (EKFON India Private Limited)		1514
24.00	Form FIR - 2: Current Contract Commitments (Gajra Infra Pvt Ltd.)		1517
25.00	Form FIR - 2: Current Contract Commitments (Ascent Engineers & Infrastructure India Pvt Ltd)		1519
26.00	Form FIR - 2: Current Contract Commitments (N.A. Construction Pvt Ltd)		1521
27.00	Form EXP-4.1 General Construction Experience (STRABAG Infrastructure & Safety Solutions GmbH)		1529
28.00	Form EXP-4.1 General Construction Experience (STRABAG AG)		1534
29.00	Electrical License		1537
	29.01	Electrical License for STRABAG Infrastructure & Safety Solutions GmbH	1538
	29.02	Electrical License for STRABAG AG	1540
30.00	Form EXP - 4.2(a) Specific Construction Experience		1554
	30.01	Project - Klaus	1555
	30.02	True copy of the completion certificate	1559
	30.03	Project - Langen	1562
	30.04	True copy of the completion certificate	1566
31.00	Form EXP - 4.2(b) Specific Construction Experience in Key Activities		1569
	31.01	Key Activity No. (1)	





## INDEX

S no	Particulars		Page No.
	31.01.01	Project 1 (Hyderabad ORR HTMS Project)	1571
	31.01.02	True copy of the completion certificate	1574
	31.01.03	Project 2 (NOIDA HTMS Project)	1576
	31.01.04	True copy of the completion certificate	1579
	31.01.05	Project 3 (Yamuna HTMS Project)	1581
	31.01.06	True copy of the completion certificate	1584
	31.01.07	Project 4 (Aligarh Smart City Project)	1586
	31.01.08	True copy of the completion certificate	1589
	31.01.09	Project 5 (Tumakuru Smart City Project)	1593
	31.01.10	True copy of the completion certificate	1596
	31.01.11	Project 6 (DnD Project)	1600
	31.01.12	True copy of the completion certificate	1603
	31.02	Key Activity No. (2)	1605
	31.02.01	Project 1 (Hyderabad ORR TMS Project)	1607
	31.02.02	True copy of the completion certificate	1610
	31.02.03	Project 2 (GRICL Project)	1612
	31.02.04	True copy of the completion certificate	1615
	31.02.05	Project 3 (BETPL Project)	1618
	31.02.06	True copy of the completion certificate	1621
	31.02.07	Project 4 (Yamuna Express Way Project)	1624
	31.02.08	True copy of the completion certificate	1627
	31.02.09	Project 5 (PSEPL Project)	1630
	31.02.10	True copy of the completion certificate	1633
	31.02.11	Project 6 (GVK Deolikota Project)	1645
	31.02.12	True copy of the completion certificate	1648
	31.03	Key Activity No. (3)	1651
	31.03.01	Project 1 (Klaus Project)	1652
	28.03.02	True copy of the completion certificate	1655
	31.04	Key Activity No. (4)	1660
	31.04.01	Project 1 (Klaus Project)	1661
	31.04.02	True copy of the completion certificate	1664

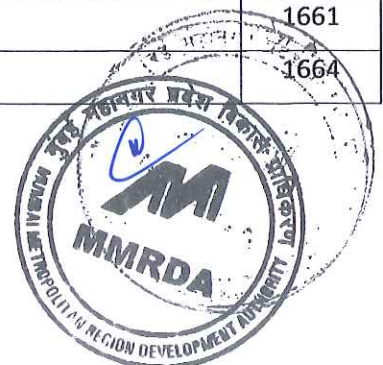



## INDEX

S no	Particulars		Page No.
	31.04.03	Project 2 (Langen Project)	1667
	31.04.04	True copy of the completion certificate	1670
	31.04.05	Project 3 (Oswaldiberg Project)	1673
	31.04.06	True copy of the completion certificate	1676
	31.05	Key Activity No. (5)	1679
	31.05.01	STRABAG AG Project 1 (ORBI Tower, TownTown)	1681
	31.05.02	True copy of the completion certificate	1684
	31.05.03	STRABAG AG Project 2 (Pavilions Parliamentary)	1687
	31.05.04	True copy of the completion certificate	1690
	31.05.05	Subcontractor 2 - N.A. Construction Pvt Ltd Project 1 (Vasai Virar City Municipal Corporation)	1693
	31.05.06	True copy of the completion certificate	1695
	31.05.07	Subcontractor 3 - Gajra Infra Pvt Ltd. Project 1 (IL&FS Khed Sinnar Expressway)	1701
	31.05.08	True copy of the completion certificate	1704
	31.05.09	Subcontractor 3 - Gajra Infra Pvt Ltd. Project 2 (Ashoka)	1722
	31.05.10	True copy of the completion certificate	1725
	31.05.11	Subcontractor 4 - Ascent Engineers & Infrastructure India Pvt Ltd Project 1 (Gammon Tumakur - Haveri)	1731
	31.05.12	True copy of the completion certificate	1734
	31.05.13	Subcontractor 4 - Ascent Engineers & Infrastructure India Pvt Ltd Project 2 (GMR)	1736
	31.05.14	True copy of the completion certificate	1739
	31.05.15	Subcontractor 4 - Ascent Engineers & Infrastructure India Pvt Ltd Project 3 (NHAI Guabari Toll Plaza)	1741
	31.05.16	True copy of the completion certificate	1744
	31.05.17	Subcontractor 4 - Ascent Engineers & Infrastructure India Pvt Ltd Project 4 (NHAI Surjapur Toll Plaza)	1746
	31.05.18	True copy of the completion certificate	1749
32.00	Technical Proposal		1751
	32.01	Site Organization	1751
		Form PER-1	1754





## INDEX

S no	Particulars	Page No.
	32.01.01 Form PER-2 - Project Manager	1758
	32.01.02 Form PER-2 - Deputy Project Manager	1763
	32.01.03 Form PER-2 - Design Manager	1770
	32.01.04 Form PER-2 - Construction Manager - Intelligent Transport System (ITS) and Toll Management System	1779
	32.01.05 Form PER-2 - Construction Manager – Electrical Works	1783
	32.01.06 Form PER-2 - Construction Manager – Civil and Buildings	1787
	32.01.07 Form PER-2 - Planning Engineer	1792
	32.01.08 Form PER-2 - Safety (Accident Prevention) Officer	1796
	32.01.09 Form PER-2 - Environment Specialist	1799
	32.01.10 Form PER-2 - Contract Specialist	1809
	32.01.11 Form PER-2 - Quality Assurance Manager	1814
	32.01.12 Form PER-2 - Administration Officer	1821
32.02	Method Statement	1827
	32.02.01 Traffic Management System & Toll Management System Toll Management System	1828
	32.02.02 MEP System	2023
32.03	Mobilization Schedule	2182
	32.03.01 Equipment List	2184
	32.03.02 Form EQU	2189
	32.03.03 Form MAN	2194
	32.03.04 Catalogues and Drawings	2206
32.04	Construction Schedule	2337
32.05	Preliminary/Bidding Design	2352
32.06	Safety Plan / Environmental Management Plan / Health Plan	2459
32.07	Quality Assurance Plan	2570
32.08	Form SOG	2643
32.09	Form SPA: Spare Parts	2645
32.10	Form SUB	2647



Form EXP - 4.2(b): Specific Construction  
Experience in Key Activities

**Key Activity No. (1): Planning, designing, implementing and integration of traffic control center system comprising information gathering, processing and dissemination functions and human machine interface with following subsystems**

(a) Emergency Call Box system with at least 6 Nos. roadside terminals

(b) Variable Message Signs System with at least 8 displays of 4 Mtr x 2 Mtr erected on the gantry

(c) Traffic and security surveillance system consisting of at least 130 Nos. PTZ cameras

(d) 2 Nos. installations of Automatic Traffic Counter and Classifier system for 3 lane projects

(e) Supply and Installation of at least 3 three Meteorological Observation station

(f) Supply and Installation of at least 130 Nos. Video Incident Detection Cameras for 3 lane projects;





## Form EXP - 4.2(b): Specific Construction Experience in Key Activities

Key Activity No. (1): Planning, designing, implementing and integration of traffic control center system comprising information gathering, processing and dissemination functions and human machine interface with following subsystems

### EFKON India Private Limited

Project 1: Hyderabad ORR HTMS
Project 2: Noida HTMS
Project 3: Yamuna HTMS
Project 4: Aligarh Smart City
Project 5: Tamakuru Smart City
Project 6: DnD





**Form EXP - 4.2(b): Specific Construction  
Experience in Key Activities**

Key Activity No. (1): Planning, designing, implementing and integration of traffic control center system comprising information gathering, processing and dissemination functions and human machine interface with following subsystems

**EFKON India Private Limited**

**Project 1: Hyderabad ORR HTMS**



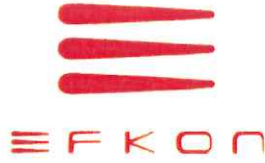

EFKON INDIA PVT. LTD., 1115, 11th Floor, Rupa Solitaire, Building No. A-1 Sector 1, Millennium Business Park, Navi Mumbai, Mahape, Thane - 400710

**Form EXP – 4.2 (b)**  
**Specific Construction Experience in Key Activities**

Date: 08<sup>th</sup> December 2021

Bidder's Legal Name: JV of STRABAG Infrastructure & Safety Solutions GmbH and STRABAG AG

Subcontractor Party Legal Name: EFKON INDIA PRIVATE LIMITED

IFB No.: MMRDA/ENG1/0002561

Page 01 of 02 pages

**Key Activity No. (1):** Planning, designing, implementing and integration of traffic control center system comprising information gathering, processing and dissemination functions and human machine interface with following subsystems

- (a) Emergency Call Box system with at least 6 Nos. roadside terminals
- (b) Variable Message Signs System with at least 8 displays of 4 Mtr x 2 Mtr erected on the gantry
- (c) Traffic and security surveillance system consisting of at least 130 Nos. PTZ cameras
- (d) 2 Nos. installations of Automatic Traffic Counter and Classifier system for 3 lane projects
- (e) Supply and Installation of at least 3 three Meteorological Observation station
- (f) Supply and Installation of at least 130 Nos. Video Incident Detection Cameras for 3 lane projects;

Contract with Similar Key Activities			
Item	Information		
Contract Identification	Design, Supply, Testing, Commissioning of equipment of Highway Traffic Management System and related Facilities for Outer Ring Road of Hyderabad City in the State of Telangana Contract No: CGM(T)/HGCL/JICA2/03/HTMS/2016-17		
Award Date	22 <sup>nd</sup> September 2016		
Completion Date	15 <sup>th</sup> March 2021		
Role in Contract	Prime Contractor		Management Contractor <input type="checkbox"/>
	Single entity <input type="checkbox"/>	JV member <input checked="" type="checkbox"/>	
Total Contract Amount	INR 51,73,15,876/-		1 INR = 0.0150 USD dated 22 <sup>nd</sup> September 2016 and total contract amount in USD equivalent is 7,743,656
Description of the Works undertaken for demonstration	<b>Hyderabad ORR HTMS is a comprehensive HTMS Project providing Planning, designing, implementing and integration of traffic control center system comprising information gathering, processing and</b>		



Registered Office:  
 EFKON INDIA PVT. LTD.  
 1115, 11th Floor, Rupa Solitaire, Building No. A-1,  
 Sector 1, Millennium Business Park, Navi Mumbai  
 Mahape, Thane - 400710  
 CIN NO.: - U72900MH2001PTC132670

Tel. :+91 22 42949494  
 Fax :+91 22 42949333  
 Web :http://www.efkonindia.com





EFKON INDIA PVT. LTD., 1115, 11th Floor, Rupa Solitaire, Building No. A-1 Sector 1, Millennium Business Park, Navi Mumbai, Mahape, Thane - 400710

of the similarity of the key activity	<p>dissemination functions and human machine interface with following subsystems.</p> <p>(a) Emergency Call Box system with 328 Nos. roadside terminals</p> <p>(b) Variable Message Signs System with at least 37 Nos displays of 6 Mtr x 2 Mtr erected on the gantry</p> <p>(c) Traffic and security surveillance system consisting of 41 Nos. PTZ cameras</p> <p>(d) 74 Nos. installations of Automatic Traffic Counter and Classifier system covering 3 lane in each direction</p> <p>(e) Supply and Installation of 4 nos. Meteorological Observation station</p> <p>(f) Supply and Installation of 41 Nos. Video Incident Detection Cameras covering 3 lane in each direction</p>
Employer's Name:	Hyderabad Growth Corridor Limited
Address:	HGCL office building, 2nd floor, Nanakramguda, Hyderabad – 500 104
Telephone/Fax Number:	+91 - 40 - 27002913
E-mail:	Email: cgmhgcl@gmail.com

- Attached is a true copy of the completion certificate or other similar document(s) for the contract / project issued by the client.

For EFKON India Private Limited,

Printed Name:

Designation:

Gurpreet Singh Basra  
Lawful Attorney



Tarun Sharma  
Lawful Attorney



Registered Office:

EFKON INDIA PVT. LTD.  
1115, 11th Floor, Rupa Solitaire, Building No. A-1,  
Sector 1, Millennium Business Park, Navi Mumbai  
Mahape, Thane - 400710  
CIN NO.: - U72900MH2001PTC132670

Tel. :+91 22 42949494  
Fax :+91 22 42949333  
Web :http://www.efkonindia.com

1573



Form EXP - 4.2(b): Specific Construction  
Experience in Key Activities

Key Activity No. (1): Planning, designing, implementing and integration of traffic control center system comprising information gathering, processing and dissemination functions and human machine interface with following subsystems

**EFKON India Private Limited**

Project 1: Hyderabad ORR HTMS

True Copy of the Completion Certificate



# HYDERABAD GROWTH CORRIDOR LIMITED

Dated: 15<sup>th</sup> April 2021

TO WHOMSOEVER IT MAY CONCERN

This to certify that Consortium of EFKON India Private Limited(EIPL) and STRABAG ANALAGENTECHNIK GMBH, having registered office at 1405-1408 SUPREMUS E Wing, I Think Techno Campus, Kanjurmarg (East), Mumbai-400042, was awarded the work of Design, Supply, Testing, Commissioning, of equipment of Highway Traffic Management System and related Facilities for Outer Ring Road to Hyderabad City in the state of Telangana, India being taken up with loan assistance of Japan International Cooperation Agency under Phase-2 program and operation & Maintenance of HTMS and Related Facilities for a period of Five years from date of operational Acceptance Certificate being taken up with HGCL Funds." vide for a Gross Contract Value Rs. 51,73,15,876/-.

Contract Agreement No : CGM(T)/HGCL/JICA2/03/HTMS/2016-17 Dated 22.09.2016  
 Date of Award : 22<sup>nd</sup> Sept' 16  
 Date of Go Live : 15<sup>th</sup> Mar' 21  
 O&M Start Date : 15<sup>th</sup> Mar' 21  
 O&M Period : 5 Years

Project description executed under this Contract is as under:

1. Length of the Stretch - 158 Kms
2. Emergency Telephone System - Emergency Call Box (ECB) - 328 Nos.
3. Variable Message Sign Boards (VMS) (6 x 2 mtrs) - 37 Nos.
4. Variable Message Sign Boards (VMS) (5 x 1.5 mtrs) - 10 Nos.
5. Environment Monitoring System - Metrology Data System - (MDS) - 04 No.
6. Automatic Traffic Counting and Classifying System (Cameras with Video Analytics) 74 Nos.
7. CCTV Cameras - 41 Nos. with Incident Detection
8. Dedicated Optical Fiber Cable (OFC) - 391.7 Km Length.
9. Digital Transmission System - 1 Nos.
10. Setting up and Management of IT Infrastructure for Tier III+ Compliant Data Centre - 1 Nos.
11. Efkon Command and Control Centre incl. Emergency Response integrating all above HTMS peripheral sensors system in the Main Traffic Control Centre at Nanakramguda Interchange & Sub Traffic Control Centre at Ghatkesar Interchange. - 02 Nos.

All the equipment supply and installation works under the contract has been satisfactorily completed. The contract is currently under Operation and Maintenance Phase. EFKON Services (Hardware Software, Services etc.) met our expectation in terms of quality, performance and delivery. The system is performing satisfactorily from date of its commissioning.

This certificate is being issued specifically for the purpose of submitting tender.

Date: 15<sup>th</sup> April 2021  
Place: Hyderabad

**TRUE COPY**

*[Signature]*  
 Chief General Manager (Tech)  
 HGC

*[Signature]*  
 Dilip N. Salve  
 ADVOCATE & NOTARY

238 9320, Marol Noida, Kanjurmarg Nagar

HGCL office Building, 2<sup>nd</sup> floor, Khujurguda Road, Adjacent to ORR, Nanakramguda, Hyderabad -500 104  
Email : [cgmhgcl@hmda.gov.in](mailto:cgmhgcl@hmda.gov.in)

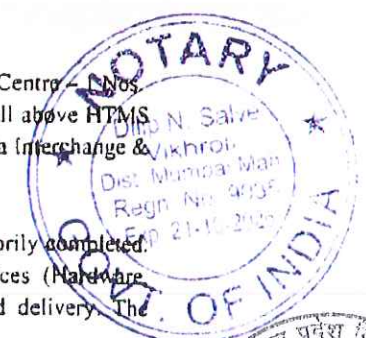



**Form EXP - 4.2(b): Specific Construction  
Experience in Key Activities**

Key Activity No. (1): Planning, designing, implementing and integration of traffic control center system comprising information gathering, processing and dissemination functions and human machine interface with following subsystems

**EFKON India Private Limited**

**Project 2: Noida HTMS**





EFKON INDIA PVT. LTD., 1115, 11th Floor, Rupa Solitaire, Building No. A-1 Sector 1, Millennium Business Park, Navi Mumbai, Mahape, Thane - 400710

**Form EXP – 4.2 (b)**  
**Specific Construction Experience in Key Activities**

Date: 08<sup>th</sup> December 2021

Bidder's Legal Name: JV of STRABAG Infrastructure & Safety Solutions GmbH and STRABAG AG

Subcontractor Party Legal Name: EFKON INDIA PRIVATE LIMITED

IFB No.: **MMRDA/ENG1/0002561**

Page 01 of 02 pages

**Key Activity No. (1):** Planning, designing, implementing and integration of traffic control center system comprising information gathering, processing and dissemination functions and human machine interface with following subsystems

- (a) Emergency Call Box system with at least 6 Nos. roadside terminals
- (b) Variable Message Signs System with at least 8 displays of 4 Mtr x 2 Mtr erected on the gantry
- (c) Traffic and security surveillance system consisting of at least 130 Nos. PTZ cameras
- (d) 2 Nos. installations of Automatic Traffic Counter and Classifier system for 3 lane projects
- (e) Supply and Installation of at least 3 three Meteorological Observation station
- (f) Supply and Installation of at least 130 Nos. Video Incident Detection Cameras for 3 lane projects;

Contract with Similar Key Activities			
Item	Information		
Contract Identification	Development, Supply, Installation, Testing & Commissioning, Operation & Maintenance of Highway Traffic Management System (HTMS) for NOIDA – Greater NOIDA Gautam Budha Expressway. Contract Agreement dated 05 <sup>th</sup> December 2013		
Award Date	05 <sup>th</sup> December 2013		
Completion Date	04 <sup>th</sup> December 2019		
Role in Contract	Prime Contractor	Management Contractor	Subcontractor
	Single entity <input checked="" type="checkbox"/>	JV member <input type="checkbox"/>	<input type="checkbox"/>
Total Contract Amount	INR 32,18,97,141/-		1 INR = 0.0182 USD dated 05 <sup>th</sup> December 2013 and total contract amount in USD equivalent is 5,872,910
Description of the Works undertaken for demonstration	<b>NOIDA – Greater NOIDA Expressway Project is a comprehensive HTMS Project providing Planning, designing, implementing and integration of traffic control center system comprising information gathering,</b>		



Registered Office:  
EFKON INDIA PVT. LTD.  
1115, 11th Floor, Rupa Solitaire, Building No. A-1,  
Sector 1, Millennium Business Park, Navi Mumbai  
Mahape, Thane - 400710  
CIN NO.: - U72900MH2001PTC132670

Tel. :+91 22 42949494  
Fax. :+91 22 42949333  
Web.:http://www.efkonindia.com

**1577**





EFKON INDIA PVT. LTD., 1115, 11th Floor, Rupa Solitaire, Building No. A-1 Sector 1, Millennium Business Park, Navi Mumbai, Mahape, Thane - 400710

of the similarity of the key activity	<p>processing and dissemination functions and human machine interface with following subsystems:</p> <p>(a) Emergency Call Box system with 24 Nos. roadside terminals</p> <p>(b) Traffic and security surveillance system consisting of 46 Nos. PTZ cameras</p> <p>(c) 3 Nos. installations of Automatic Traffic Counter and Classifier system covering 3 lane in each direction</p> <p>(d) Supply and Installation of 1 nos. Meteorological Observation station</p> <p>(e) Supply and Installation of 15 Nos. Video Incident Detection Cameras covering 3 lane in each direction</p>
Employer's Name:	New Okhla Industrial Development Authority
Address:	Main Administrative Building, Sector- VI, Noida, Dist. Gautam Budh Nagar -201301
Telephone/Fax Number:	+91 - 120 2425025
E-mail:	nizam@noidaauthorityonline.com

- Attached is a true copy of the completion certificate or other similar document(s) for the contract / project issued by the client.

For EFKON India Private Limited,

Printed Name:  
Designation:

Gurpreet Singh Basra  
Lawful Attorney



Tarun Sharma  
Lawful Attorney

*Tarun Sharma*



Registered Office:  
EFKON INDIA PVT. LTD.  
1115, 11th Floor, Rupa Solitaire, Building No. A-1,  
Sector 1, Millennium Business Park, Navi Mumbai  
Mahape, Thane - 400710  
CIN NO.: - U72900MH2001PTC132670

Tel. :+91 22 42949494  
Fax :+91 22 42949333  
Web.:http://www.efkonindia.com

1578

**Form EXP - 4.2(b): Specific Construction  
Experience in Key Activities**

Key Activity No. (1): Planning, designing, implementing and integration of traffic control center system comprising information gathering, processing and dissemination functions and human machine interface with following subsystems

**EFKON India Private Limited**

**Project 2: Noida HTMS**

**True Copy of the Completion Certificate**





नवीन ओखला औद्योगिक विकास प्राधिकरण



NEW OKHLA INDUSTRIAL DEVELOPMENT AUTHORITY

Main Administration Building

Sector 10, Noida, Dist. Gautam Buddha Nagar, 201301



No Noida/Sr Manager(E&M)-IV/2019/152  
Date 10/12/19

TO WHOM IT MAY CONCERN

This is to Certify that M/s. Efkon India Pvt. Ltd., 1405 - 1408, 14th Floor, Supremus, E - wing, Think Techno Campus, Kanjur Village Road, Kanjur Marg (East), Mumbai. 400042 has executed the following work as per record of this division

- Name of the work: Development, supply, installing, testing and commissioning operation and maintenance of advanced traffic management system for NOIDA - GREATER NOIDA Gautam Budha Expressway from Maha Maya Flyover to Pari Chowk.
- C.B. No: 01/SPE/PE/PE/E&M-III/13-14, DT - 05 12 2013
- Date of Start: 05 12 2013
- Date of Operation: 04 12 2014 to 04 12 2019
- As per C.B. Amount: Rs. 26,85,81,335.00/- only, this includes the AMC of five years which is till 04 12 2019
- Total Project Value: Rs. 32,18,97,141.50/- only, this includes the main contract value & AMC, running operation cost & etc for five years upto 04 12 2019.

The Project includes:

- Video Incident Detection System (VIDS) - Cameras 15 Nos
- Automatic Number Plate Recognition System for Speed Enforcement - Cameras 24 Nos.
- Emergency Telephone System - Emergency Call Box (ECB) - 24 Nos
- Variable Message Sign Boards (VMS) - 13 Nos.
- Weather Monitoring System - Meteorology Data System - (MDS) - 01 No
- Video based Automatic Traffic Counting and Classifying System (ATCC-V) - 04 Nos. with 4 nos. sensors
- CCTV (Closed Circuit Television) Monitoring System Cameras - 138 Nos
- Dedicated O.F.C network - 60 Km
- E - challan System for automatic challan generation for Traffic violations
- Video Wall for live monitoring the feeds and incidents detected by field sensors.
- Data Centre Tier 3
- Command and Control Application and Integration of all peripheral components
- GIS maps integrated with Command and Control.
- Online portal and Mobile Application (DRIVE SMART) services for public & govt. authorities for incident reporting and providing real time feed and information
- 24x7 O&M, Helpdesk with Seating capacity of 21 people for dispatching rescue team in case of emergency.
- Accident Response System

The overall experience & project performance from EFKON INDIA PVT. LTD. is satisfactory



(Dr Nizamuddin)  
Sr. Manager(E/M)-IV Noida

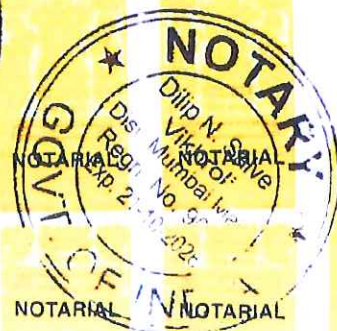

TRUE COPY

Dilip N. Salve  
ADVOCATE & N...



Form EXP - 4.2(b): Specific Construction  
Experience in Key Activities

Key Activity No. (1): Planning, designing, implementing and integration of traffic control center system comprising information gathering, processing and dissemination functions and human machine interface with following subsystems

**EFKON India Private Limited**

**Project 3: Yamuna HTMS**







EFKON INDIA PVT. LTD., 1115, 11th Floor, Rupa Solitaire, Building No. A-1 Sector 1, Millennium Business Park, Navi Mumbai, Mahape, Thane - 400710

**Form EXP – 4.2 (b)**  
**Specific Construction Experience in Key Activities**

Date: 08<sup>th</sup> December 2021

Bidder's Legal Name: JV of STRABAG Infrastructure & Safety Solutions GmbH and STRABAG AG

Subcontractor Party Legal Name: EFKON INDIA PRIVATE LIMITED

IFB No.: **MMRDA/ENG1/0002561**

Page 01 of 02 pages

**Key Activity No. (1):** Planning, designing, implementing and integration of traffic control center system comprising information gathering, processing and dissemination functions and human machine interface with following subsystems

- (a) Emergency Call Box system with at least 6 Nos. roadside terminals
- (b) Variable Message Signs System with at least 8 displays of 4 Mtr x 2 Mtr erected on the gantry
- (c) Traffic and security surveillance system consisting of at least 130 Nos. PTZ cameras
- (d) 2 Nos. installations of Automatic Traffic Counter and Classifier system for 3 lane projects
- (e) Supply and Installation of at least 3 three Meteorological Observation station
- (f) Supply and Installation of at least 130 Nos. Video Incident Detection Cameras for 3 lane projects;

Contract with Similar Key Activities			
Item	Information		
Contract Identification	Design, Supply, Installation and commissioning of Highway Traffic Management System and Speed Enforcement System for the Yamuna Expressway – a stretch of 165 Km Multilane Highway, in the state of Uttar Pradesh, India. PO Ref No.: JAL/YEP/CP-1/2/3/3672, JAL/YEP/CP-1/2/3/3673, JAL/YEP/CP-1 /2/3/3671, JAL/YEP /CP-1/2/3//3679		
Award Date	March 2012		
Completion Date	August 2012		
Role in Contract	Prime Contractor		Management Contractor <input type="checkbox"/>
	Single entity <input checked="" type="checkbox"/>	JV member <input type="checkbox"/>	
Total Contract Amount	INR 18,17,84,608/-		1 INR = 0.0203 USD dated 12 <sup>th</sup> March 2012 and total contract amount in USD equivalent is 3,698,763



*[Handwritten signature]*



*[Handwritten signature]*



Registered Office:

EFKON INDIA PVT. LTD.

1115, 11th Floor, Rupa Solitaire, Building No. A-1,

Sector 1, Millennium Business Park, Navi Mumbai

Mahape, Thane - 400710

CIN NO.: - U72900MH2001PTC132670

Tel. :+91 22 42949494

Fax :+91 22 42949333

Web.:http://www.efkonindia.com

**1582**



EFKON INDIA PVT. LTD., 1115, 11th Floor, Rupa Solitaire, Building No. A-1 Sector 1, Millennium Business Park, Navi Mumbai, Mahape, Thane - 400710

Description of the Works undertaken for demonstration of the similarity of the key activity	<p><b>Yamuna Expressway HTMS Project is comprehensive HTMS providing Planning, designing, implementing and integration of traffic control center system comprising information gathering, processing and dissemination functions and human machine interface with following subsystems:</b></p> <p>(a) Emergency Call Box system with 84 Nos. roadside terminals  (b) Variable Message Signs System with at least 8 Nos displays of 4 Mtr x 2 Mtr erected on the gantry  (c) Traffic and security surveillance system consisting of 19 Nos. PTZ cameras  (d) Supply and Installation of 4 nos. Meteorological Observation station  (e) Supply and Installation of 25 Nos. Video Incident Detection Cameras covering 3 lane in each direction</p>
Employer's Name:	Jaiprakash Associates Limited
Address:	Sector- 128, Noida- 201304, Uttar Pradesh
Telephone/Fax Number:	Ph No: (120) 4609000, 2470800 / Fax: (120) 4609464, 4609496
E-mail:	santosh.pawar@jalindia.co.in

Attached is a true copy of the completion certificate or other similar document(s) for the contract / project issued by the client.

For EFKON India Private Limited,

Printed Name:  
Designation:

  
Gurpreet Singh Basra  
Lawful Attorney

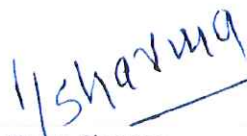

  
Tarun Sharma  
Lawful Attorney



Registered Office:  
EFKON INDIA PVT. LTD.  
1115, 11th Floor, Rupa Solitaire, Building No. A-1,  
Sector 1, Millennium Business Park, Navi Mumbai  
Mahape, Thane - 400710  
CIN NO.: - U72900MH2001PTC132670

Tel. :+91 22 42949494  
Fax :+91 22 42949333  
Web: http://www.efkonindia.com





Form EXP - 4.2(b): Specific Construction  
Experience in Key Activities

Key Activity No. (1): Planning, designing, implementing and integration of traffic control center system comprising information gathering, processing and dissemination functions and human machine interface with following subsystems

**EFKON India Private Limited**

Project 3: Yamuna HTMS

True Copy of the Completion Certificate



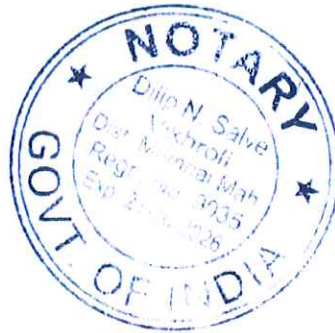

**JAYPEE  
INFRATECH**

01<sup>st</sup> May 2014

**To Whom It May Concern**

Ekon India Pvt. Ltd. was awarded the work of Design, Supply, Installation and Commissioning of Highway Traffic Management System (HTMS) and Speed Enforcement System for the Yamuna Expressway – a stretch of 165 KM multilane Highway, in the State of Uttar Pradesh vide Work Order dated 1<sup>st</sup> March 2012.

The system installation was completed in August 2012 and is currently operational.

The HTMS system and Speed Enforcement System (including section control) comprises of following sub-systems:

- |   |   |  |
|---|---|--|
| 1. Fixed Variable Message Signs               | : | 8 nos.   |
| 2. Mobile Variable message signs              | : | 6 nos.   |
| 3. Toll Lane Display Variable Message Signs   | : | 54 nos.  |
| 4. Emergency Call Boxes                       | : | 82 Pairs i.e. 164 units                                  |
| 5. Weather monitoring Meteorological stations | : | 4 nos.   |
| 6. CCTV PTZ Cameras                           | : | 19 nos.  |
| 7. Video Incident Detection Systems           | : | 25 nos.  |
| 8. Speed Enforcement Cameras with ANPR        | : | 30 nos.  |
| 9. Lane ANPR Cameras                          | : | 54 nos.  |
| 10. Highway Traffic Surveillance Control Room | : | 2 locations (1 main control room and 1 Sub-control room) |

The total contract value is INR Rs. 18,17,84,608 - (Rupees Eighteen Crore, Seventeen Lakhs, Eighty Four thousand, Six Hundred Eight Only).

*[Signature]*  
For Jaypee Infratech Limited,

**JAYPEE INFRATECH LIMITED**

Col. (Retd.) Vikash Uniyal  
GM (Toll Management System)-YLP

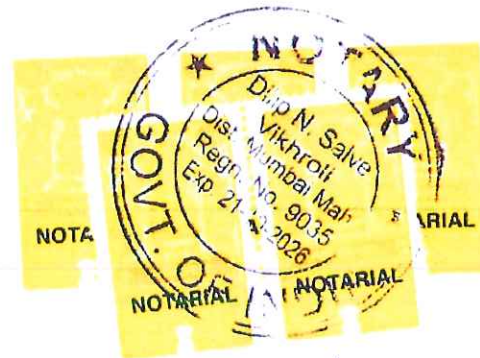

**TRUE COPY**

*[Signature]*  
Dilip N. Salve  
ADVOCATE & NOTARY  
208/9379, Mansa Bhg, Kannaikar Nagar  
No. 2, Vikhroli, Mumbai - 400 083



**JAYPEE INFRATECH LIMITED**  
Regd. Office Sector - 128, Noida - 201304, Uttar Pradesh (India)  
Ph -91 (120) 2470800 Fax -91 (0120) 2470887 Website [www.jalindia.com](http://www.jalindia.com)





**Form EXP - 4.2(b): Specific Construction  
Experience in Key Activities**

Key Activity No. (1): Planning, designing, implementing and integration of traffic control center system comprising information gathering, processing and dissemination functions and human machine interface with following subsystems

**EFKON India Private Limited**

**Project 4: Aligarh Smart City**





EFKON INDIA PVT. LTD., 1115, 11th Floor, Rupa Solitaire, Building No. A-1 Sector 1, Millennium Business Park, Navi Mumbai, Mahape, Thane - 400710

**Form EXP – 4.2 (b)**  
**Specific Construction Experience in Key Activities**

Date: 08<sup>th</sup> December 2021

Bidder's Legal Name: JV of STRABAG Infrastructure & Safety Solutions GmbH and STRABAG AG

Subcontractor Party Legal Name: EFKON INDIA PRIVATE LIMITED

IFB No.: **MMRDA/ENG1/0002561**

Page 01 of 02 pages

**Key Activity No. (1):** Planning, designing, implementing and integration of traffic control center system comprising information gathering, processing and dissemination functions and human machine interface with following subsystems

- (a) Emergency Call Box system with at least 6 Nos. roadside terminals
- (b) Variable Message Signs System with at least 8 displays of 4 Mtr x 2 Mtr erected on the gantry
- (c) Traffic and security surveillance system consisting of at least 130 Nos. PTZ cameras
- (d) 2 Nos. installations of Automatic Traffic Counter and Classifier system for 3 lane projects
- (e) Supply and Installation of at least 3 three Meteorological Observation station
- (f) Supply and Installation of at least 130 Nos. Video Incident Detection Cameras for 3 lane projects;

Contract with Similar Key Activities			
Item	Information		
Contract Identification	Selection of System Integrator for Implementation of Integrated Command and Control Centre and E-Governance based smart city solutions at Aligarh Contract Agreement dated 26 <sup>th</sup> July 2019		
Award Date	26 <sup>th</sup> July 2019		
Completion Date	03 <sup>rd</sup> February 2021 (Go Live)		
Role in Contract	Prime Contractor		Management Contractor <input type="checkbox"/>
	Single entity <input type="checkbox"/>	JV member <input checked="" type="checkbox"/>	
Total Contract Amount	INR 1,17,53,63,203/-		1 INR = 0.0145 USD dated 26 <sup>th</sup> July 2019 and total contract amount in USD equivalent is 17,059,250
Description of the Works undertaken for demonstration of the similarity of the key activity	Aligarh Smart City Project is a comprehensive Smart City Project providing Planning, designing, implementing and integration of traffic control center system comprising information gathering, processing and		

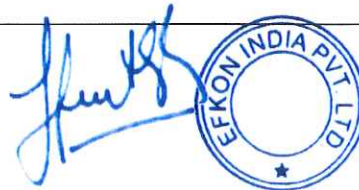

Registered Office:

EFKON INDIA PVT. LTD.  
1115, 11th Floor, Rupa Solitaire, Building No. A-1,  
Sector 1, Millennium Business Park, Navi Mumbai  
Mahape, Thane - 400710  
CIN NO.: - U72900MH2001PTC132670

Tel. :+91 22 42949494

Fax :+91 22 42949333

Web: <http://www.efkonindia.com>

**1587**





003618

EFKON INDIA PVT. LTD., 1115, 11th Floor, Rupa Solitaire, Building No. A-1 Sector 1, Millennium Business Park, Navi Mumbai, Mahape, Thane - 400710

	<b>dissemination functions and human machine interface with following subsystems.</b>  <b>(a) Emergency Call Box system with 40 Nos. roadside terminals</b> <b>(b) Traffic and security surveillance system consisting of 63 Nos. PTZ cameras</b> <b>(c) 74 Nos. installations of Automatic Traffic Counter and Classifier system covering 3 lane in each direction</b> <b>(d) Supply and Installation of 1 nos. Meteorological Observation station</b> <b>(e) Supply and Installation of 227 Nos. Video Incident Detection Cameras covering 3 lane in each direction</b>
Employer's Name:	Aligarh Smart City Limited
Address:	Aligarh Nagar Nigam, Sewa Bhawan, Aligarh – 202001, Uttar Pradesh
Telephone/Fax Number:	+91 - 0571 240 5520
E-mail:	aligarhsmartcityltd@gmail.com

Attached is a true copy of the completion certificate or other similar document(s) for the contract / project issued by the client.

For EFKON India Private Limited,

Gurpreet Singh Basra  
Lawful Attorney



Tarun Sharma  
Lawful Attorney

Printed Name:  
Designation:



Registered Office:  
EFKON INDIA PVT. LTD.  
1115, 11th Floor, Rupa Solitaire, Building No. A-1,  
Sector 1, Millennium Business Park, Navi Mumbai  
Mahape, Thane - 400710  
CIN NO.: - U72900MH2001PTC132670

Tel. :+91 22 42949494  
Fax :+91 22 42949333  
Web.:http://www.efkonindia.com

1588

**Form EXP - 4.2(b): Specific Construction  
Experience in Key Activities**

Key Activity No. (1): Planning, designing, implementing and integration of traffic control center system comprising information gathering, processing and dissemination functions and human machine interface with following subsystems

**EFKON India Private Limited**

**Project 4: Aligarh Smart City**

**True Copy of the Completion Certificate**







ALIGARH SMART CITY LIMITED

CORPORATE OFFICE: MANSI GANGA BUILDING, BARALLA BYPASS ROAD,

ALIGARH-20200

CIN-U 75231UP2017SGC096467, EMAIL: [aligarhsmartcityltd@gmail.com](mailto:aligarhsmartcityltd@gmail.com)

**PROJECT**

Aligarh Smart City



**CUSTOMER :**

Aligarh Smart City Limited (ASCL)

**MSI :** Consortium of STRABAG AG, EFKON India Private Limited and ABM Knowledgeware Limited

**CONTRACT TOTAL :**

Total contract value – INR 117.53 Cr

**CONTRACT STATUS :**

Implementation phase completed, Project under O&M period.

**CONTRACT REFERENCE NO:**

Contract against RFP no. 14/ASCL/2018-19 dated 5<sup>th</sup> December 2018

**PROJECT SCOPE :**

Implementation of Integrated Command & Control Center and E-Governance based Smart City Solution at Aligarh

**PROJECT PERIOD :**

Date of Start – 26<sup>th</sup> July 2019  
Date of Go-Live – 03<sup>rd</sup> February 2021

**OPERATION & MAINTENANCE PERIOD :**

60 Months

**PROJECT DESCRIPTION :**

RFP for Implementation of Integrated Command & Control Center and E-Governance based Smart City Solution at Aligarh.

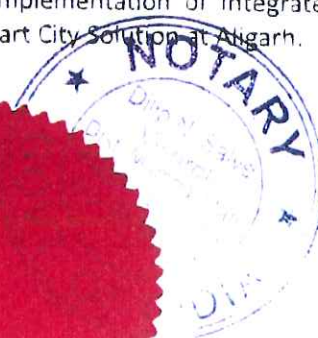



## ALIGARH SMART CITY LIMITED

CORPORATE OFFICE: MANSI GANGA BUILDING, BARAULA BYPASS ROAD,  
ALIGARH-202001

CIN-U75231UP2017SGC096467, EMAIL: [aligarhsmartcity.ltd@gmail.com](mailto:aligarhsmartcity.ltd@gmail.com)

## GENERAL DATA :

➤ **Adaptive Traffic Control System (ATCS) (at 20 Junctions)**

1. ATCS Traffic Controller – 20 Nos.
2. Adaptive Traffic Control System Controller Software – 2 Lot.
3. Vehicle Detector Camera (Automatic Traffic Counters & Classification) – 74 Nos.
4. UPS with batteries with Outdoor junction box – 20 Nos.
5. Edge level ruggedized Switches (Managed) for junction – 20 Nos.

➤ **General Surveillance System**

1. PTZ Cameras system with complete mounting accessories – 63 Nos.
2. Fixed Camera with complete mounting accessories (also for Video Incident Detection / AI based Analytic covering 3 lanes in each direction of travel) – 227 Nos.
3. Fixed Camera (Facial Recognition) – 10 Nos.
4. Face recognition software with required licenses – 1 Lot.
5. Drones with camera system – 3 Nos.
6. Video management System – 303 Licenses
7. AI based Video Analytics Software covering 3 lanes in each direction of travel – 454 Licenses (Analytics - Face Recognition, Attribute Based Search, Loitering detection, Improper Parking, Camera Tampering, Abandoned objects detection, Tripwire / intrusion and Motion detection)
8. UPS with batteries with Outdoor junction box – 44 Nos.
9. Edge level ruggedized Switches (Managed) for junction – 66 Nos.

➤ **Variable Message Sign Boards, PA System, ECB & Environmental Sensors**

1. Variable Message Sign Boards (3m x 1m) including controller – 25 Nos.
2. Variable Message Signage Software – 1 Lot.
3. Public Announcement System with required mounts and accessories – 40 Nos.
4. Emergency Call Box with complete hardware and accessories – 40 Nos.
5. PA System & ECB Software – 1 Lot.
6. Environmental Sensor System with required mounts and accessories – 10 Nos.
7. Environmental Sensor Software – 1 Lot.

➤ **Traffic Enforcement System (at 24 Junctions)**

1. Red Light Violation Detection Cameras – 74 Nos.
2. Red Light Violation Detection Software License – 1 Lot.
3. Automatic Number plate Recognition Cameras – 108 Nos.
4. Automatic Number plate Recognition Software License – 1 Lot.
5. Speed Detection Cameras with complete accessories – 16 Nos.
6. Handheld devices for spot e-challan with e-Challan App (NIC Integrated) – 40 Nos.
7. E-Challan Software License (NIC - VAHAN & SARATHI Integrated) – 1 Lot.

➤ **Setting up of Tier 3+ Compliant Data Centre along with Disaster Recovery Centre**

1. Servers – 10 Nos.
2. Operating System & Database Licenses – 1 Nos.
3. Switches - L3 Switches – 2 Nos., L2 Switches (24 Port) – 6 Nos.
4. UPS System with capacity of 100 kVA – 2 Nos.
5. DG Set – 2 Nos.
6. BMS (AC, WLD, ACS, FAS, Rodent & Repellant, False Flooring & Ceiling etc.) – 1 Lot.
7. Primary and Secondary Storage with SAN Switch – 1 Lot.

➤ **Network Connectivity**

Fibre Network (ring topology approx. 250 KM for 600+ Nodes) including trenching, supplying, laying, commissioning, testing and active components



TRUE COPY

Dilip N. Salve  
ADVOCATE & NOTARY

238/239, Main Road, CHS, Khar West, Mumbai  
Tel: 022-26111111, 26111112, 26111113

Page 2 of 5





ALIGARH SMART CITY LIMITED

CORPORATE OFFICE, MANSI GANGA BUILDING, BARALLA BYPASS ROAD,  
ALIGARH-202001

CIN-U75231UP2017SGC096467, EMAIL: [aligarhsmartcityltd@gmail.com](mailto:aligarhsmartcityltd@gmail.com)

GENERAL DATA :

➤ **CCC and other Applications**

- 1. EFKON Command and Control Software with Big-data Correlation engine - 1 Lot.
- 2. GIS Platform - 1 Lot.
- 3. Post Incident Analysis & Enterprise Management System including Helpdesk and Asset Management System - 1 Lot.
- 4. Centralized Software - ANPR, RLVD & SVD, Event Aggregation, User Management, smart dashboard and client licenses - 2 Lot

➤ **Setting up of Integrated Command and Control Centre**

- 1. Monitoring workstations - 16 Nos.
- 2. Video Wall (5x3) for CCC Building - 1 Nos.
- 3. Video Wall (2x2) for Municipal Building - 1 Nos.
- 4. Internal Dome Camera - 12 Nos.
- 5. PTZ for ICCC Building - 1 Nos.
- 6. ICCC equipment's including Laptop, IP Phone, Video conferencing, Projector, Laser smart Control room interior & Furniture, Smartphones, Finger print reader, etc. - 1 Lot

➤ **Data Digitization**

- 1. Data Digitization by Scanning, importing using OCR, manual entry

➤ **eGov Application**

- 1. ERP Modules for Finance Management, HRMS, Project Management, Tax Management, Utility Billing, Audit Management & vigilance, Knowledge Management, Custom modules, Registration & Licensing module with, ASCL Portal and Mobile app platform, Digital Signatures, Biometric attendance application with licenses

➤ **Dedicated Manpower**

- 1. For Implementation Phase - 25 Nos.
- 2. For Operation & Maintenance Phase - 31 Nos.

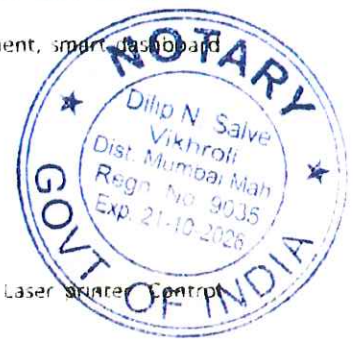

As a client Aligarh Smart City Limited (ASCL), we confirm that entire supply of equipment's, installation works under the contract has been satisfactorily completed. M/s EFKON India Private Limited services (Design, supply, and installation & commissioning of Hardware, Software, Services etc.) met our expectations in terms of quality performance and delivery. The system is performing satisfactorily from the date of its commissioning. No penalty has been applicable till date during the execution period or O&M period. The system is performing satisfactorily from date of its commissioning.

This Certificate is issued as per the request of EFKON India Private Limited for the purpose of submitting as a testimonial for bids and does not have any commercial, contractual or legal binding on Aligarh Smart City Limited (ASCL)

Rajendra Prasad

Additional Chief Executive Officer, Aligarh Smart City Limited

ALIGARH SMART CITY LIMITED  
 Mansi Ganga Building, Baralla Bypass Road,  
 Aligarh - 202001

TRUE COPY

Page 3

*Dilip N. Salve*  
 Dilip N. Salve  
 ADVOCATE & NOTARY

110/93/11, M. S. Road, Kachinwar Nagar,  
 Aligarh - 202001, U.P. India. Ph: 9354103333.



1592



**Form EXP - 4.2(b): Specific Construction  
Experience in Key Activities**

Key Activity No. (1): Planning, designing, implementing and integration of traffic control center system comprising information gathering, processing and dissemination functions and human machine interface with following subsystems

**EFKON India Private Limited**

**Project 5: Tumakuru Smart Ctiy**







EFKON INDIA PVT. LTD., 1115, 11th Floor, Rupa Solitaire, Building No. A-1 Sector 1, Millennium Business Park, Navi Mumbai, Mahape, Thane - 400710

**Form EXP – 4.2 (b)**  
**Specific Construction Experience in Key Activities**

Date: 08<sup>th</sup> December 2021

Bidder's Legal Name: JV of STRABAG Infrastructure & Safety Solutions GmbH and STRABAG AG

Subcontractor Party Legal Name: EFKON INDIA PRIVATE LIMITED

IFB No.: MMRDA/ENG1/0002561

Page 01 of 02 pages

**Key Activity No. (1):** Planning, designing, implementing and integration of traffic control center system comprising information gathering, processing and dissemination functions and human machine interface with following subsystems

- (a) Emergency Call Box system with at least 6 Nos. roadside terminals
- (b) Variable Message Signs System with at least 8 displays of 4 Mtr x 2 Mtr erected on the gantry
- (c) Traffic and security surveillance system consisting of at least 130 Nos. PTZ cameras
- (d) 2 Nos. installations of Automatic Traffic Counter and Classifier system for 3 lane projects
- (e) Supply and Installation of at least 3 three Meteorological Observation station
- (f) Supply and Installation of at least 130 Nos. Video Incident Detection Cameras for 3 lane projects;

Contract with Similar Key Activities			
Item	Information		
Contract Identification	Implementation of Pan City Integrated ICT Solutions including Establishment of Integrated City management Control Center in Tumakuru Contract Agreement dated 23 <sup>rd</sup> November 2018		
Award Date	23 <sup>rd</sup> November 2018		
Completion Date	01 <sup>st</sup> July 2021 (Go Live)		
Role in Contract	Prime Contractor		Management Contractor <input type="checkbox"/>
	Single entity <input type="checkbox"/>	JV member <input checked="" type="checkbox"/>	
Total Contract Amount	INR 47,16,47,473/-		1 INR = 0.0139 USD dated 23 <sup>rd</sup> November 2018 and total contract amount in USD equivalent is 6,555,040
Description of the Works undertaken for demonstration of the similarity of the key activity	Tumakuru Smart City Project is a comprehensive Smart City Project providing Planning, designing, implementing and integration of traffic control center system comprising information gathering, processing and		



*1/shayma*



Registered Office:

EFKON INDIA PVT. LTD.

1115, 11th Floor, Rupa Solitaire, Building No. A-1,  
Sector 1, Millennium Business Park, Navi Mumbai  
Mahape, Thane - 400710

CIN NO.: - U72900MH2001PTC132670

Tel. : +91 22 42949494

Fax : +91 22 42949333

Web.: <http://www.efkonindia.com>

**1594**



EFKON INDIA PVT. LTD., 1115, 11th Floor, Rupa Solitaire, Building No. A-1 Sector 1, Millennium Business Park, Navi Mumbai, Mahape, Thane - 400710

	<p>dissemination functions and human machine interface with following subsystems.</p> <p>(a) Emergency Call Box system with 8 Nos. roadside terminals</p> <p>(b) Traffic and security surveillance system consisting of 33 Nos. PTZ cameras</p> <p>(c) Supply and Installation of 1 nos. Meteorological Observation station</p> <p>(d) Supply and Installation of 41 Nos. Video Incident Detection Cameras covering 3 lane in each direction</p>
Employer's Name:	Tumakuru Smart City Limited
Address:	Sri Mahalakshmi Arcade, S.S. Puram Main Road, Coffee Board Colony, Tumakuru - 572102
Telephone/Fax Number:	+91 - 0816-2278190
E-mail:	office@smartcitytumakuru.in

- Attached is a true copy of the completion certificate or other similar document(s) for the contract / project issued by the client.

For EFKON India Private Limited,

Printed Name:  
Designation:

Gurpreet Singh Basra  
Lawful Attorney



Tarun Sharma  
Lawful Attorney

*Tarun Sharma*



Registered Office:  
EFKON INDIA PVT. LTD.  
1115, 11th Floor, Rupa Solitaire, Building No. A-1,  
Sector 1, Millennium Business Park, Navi Mumbai  
Mahape, Thane - 400710  
CIN NO.: - U72900MH2001PTC132670

Tel. :+91 22 42949494  
Fax :+91 22 42949333  
Web.:http://www.efkonindia.com



1595



**Form EXP - 4.2(b): Specific Construction  
Experience in Key Activities**

Key Activity No. (1): Planning, designing, implementing and integration of traffic control center system comprising information gathering, processing and dissemination functions and human machine interface with following subsystems

**EFKON India Private Limited**

**Project 5: Tumakuru Smart City**

**True Copy of the Completion Certificate**





# Tumakuru Smart City Limited, Tumakuru.

Sri Mahalakshmi Arcade, S S Puram Main Road, Coffee Board Colony, Tumakuru-572102

Website: www.smartcitytumakuru.in

Phone: 0816-2278190

e-mail : office@smartcitytumakuru.in

CIN : U74999KA2017PLC099774

## PROJECT

Tumakuru Smart City



### CUSTOMER :

Tumakuru Smart City Limited (TSCL)

**MSI :** Consortium of EFKON India Private Limited along with EFKON GmbH and Sujata Computers Private Limited

### CONTRACT TOTAL :

Total contract value – INR 47.16 Cr

### CONTRACT STATUS :

Implementation phase completed, Project under O&M period.

### CONTRACT REFERENCE NO:

Contract dated 23<sup>rd</sup> November 2018 against RFP no. TSCL/Tender/CR/38/2017-18 dated 20<sup>th</sup> September 2018

### PROJECT SCOPE :

Implementation of Pan City Integrated ICT Solutions including Establishment of Integrated City Management Control Centre in Tumakuru

### PROJECT PERIOD :

Date of Start – 31<sup>st</sup> October 2018

Date of Go-Live – 01<sup>st</sup> July 2021

### OPERATION & MAINTENANCE PERIOD :

60 Months



### PROJECT DESCRIPTION :

RFP for Implementation of Pan City Integrated ICT Solutions including Establishment of Integrated City Management Control Centre in Tumakuru



Page 1 of 3

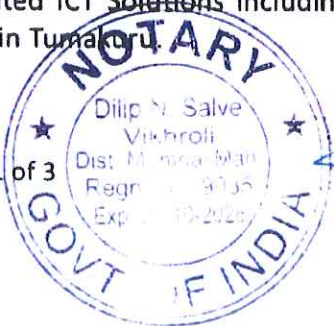





## Tumakuru Smart City Limited, Tumakuru.

Sri Mahalakshmi Arcade, S S Puram Main Road, Coffee Board Colony, Tumakuru-572102

Website: www.smartcitytumakuru.in

Phone: 0816-2278190

e-mail : office@smartcitytumakuru.in

CIN : U74999KA2017PLC099774

### GENERAL DATA :

#### ➤ Intelligent Signaling System (8 Junctions)

1. Adaptive Traffic Control System Controller – 7 Nos.
2. Adaptive Traffic Control System Controller Software – 1 Lot.
3. E Challan Application License (NIC - VAHAN & SARATHI Integrated) – 1 Lot.
4. E Challan hand-held device – 40 Nos.
5. PTZ Cameras with IR Illuminators – 16 Nos.
6. Fixed Camera with IR Illuminators – 8 Nos.
7. UPS with batteries – 8 Nos.
8. Public Address System & Emergency Call Box – 8 Nos.
9. Traffic Light Aspects & Pedestrian Lamps – (RED, Amber – 62 Nos, Green – 55 Nos, Pedestrian – 54 Nos).
10. Smart Tablet (7" screen size) for Traffic Police – 40 Nos.
11. Solar Panel and associated fitments for Traffic Lights – 66 Sets

#### ➤ CCTV City Surveillance

1. ANPR Cameras along with ANPR Software License – 31 Nos. (at 8 Junctions)
2. RLVD Camaras along with RLVD Software License – 8 Nos. (at 8 Junctions)
3. PTZ Cameras with IR Illuminators – 17 Nos.
4. Dashboard Cameras for PCR Vans – 5 Nos.
5. Video Management System License – 80 Nos.
6. AI based Video Analytics License – 80 Nos. (Analytics - Facial Recognition, Parking Violation, Wrong Direction, People loitering, Camera Tampering, Unattended Object, Crowd detection, Traffic flow/Congestion, Counter Flow and Movement)
7. UPS with batteries – 17 Nos.
8. Mobile Surveillance Vehicle with all accessories and components – 3 Nos.

#### ➤ Emergency Response System

1. Computer Aided Dispatch System for Centralized DC and DR – 2 Nos.
2. Vehicle Tracking Units for Ambulance, Fire and Police vehicles – 10 Nos.
3. Voice Broadcasting Software for Centralized DC & DR – 2 Nos.
4. Desktops with Triple Monitors – 5 Nos
5. Desktops with Single Monitors – 6 Nos
6. Mobile Data Terminals – 8 Nos
7. Interactive Voice Response Software & Automated Call Distribution Software for Centralized DC and DR & Answering Service software – 2 set
8. IP PBX -1
9. UPS Online UPS 1 kVA – 11 Nos
10. ERS- Under UAT

#### ➤ Environment Monitoring

1. Environment Sensors with Application – 5 Nos.
2. Multi Colour LED Boards (for displaying pollution info, ADS and Govt. Messages) – 5 Nos.

#### ➤ Variable Messaging System

1. VMS Boards including VMS Controllers – 6 Nos.
2. VMS Application for Centralized DC & DR – 2 Nos.







# Tumakuru Smart City Limited, Tumakuru.

No. Mahalakshmi Arcade, S.S.Puram Main Road, 1st Floor, Board Customs, Tumakuru - 575 001.  
 Website: www.smartcitytumakuru.in Phone: 0816-2278190  
 e-mail: office@smartcitytumakuru.in CIN: U74999KA2017PLC099774

**GENERAL DATA :**

➤ **Setting up of Integrated City Management Control Centre**

1. EFKON Command and Control Centre Software
2. Integrated Mobile Application
3. Video Wall (4x2), Video Wall Controller & Application
4. Internal CCTV System
5. Fire Alarm and Suppression System
6. Fiber LAN Connectivity between ICMCC & Satellite Centre
7. Video Conferencing
8. Security Infrastructure – AAA
9. Biometric Access Control System
10. Video Management Software – Base License
11. Projector for Meeting Room with Screen



➤ **Setting up of Tier 3+ Compliant Data Centre along with Disaster Recovery Centre**

1. Network Infrastructure (incl. Switches, Routers, UPS, Racks etc)
2. SAN Storage with SAN Switch
3. IP EPABX & IP Phones
4. Internal and External Firewall, Internet and WAN Routers
5. Enterprise Management System (EMS) Software + Helpdesk
6. Network Management System (NMS)
7. Redundant Online UPS - 40 KVA (Minimum) with battery backup
8. Diesel Genset.
9. Building Management System.
10. Air-conditioning System, Fire Alarm and Suppression System

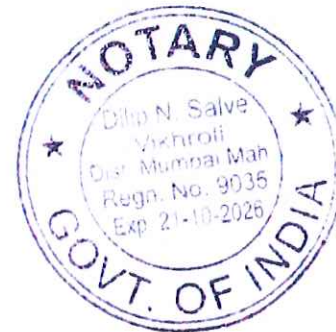

➤ **Other Substantial deliverable include**

1. Dedicated Manpower for Project Implementation, Operation & Maintenance for 5 years
2. Internet and Bandwidth Connectivity
3. Operation & Maintenance of complete project for 5 years.

As a client Tumakuru Smart City Limited (TSCL), we confirm that entire supply of equipment's, installation works under the contract has been satisfactorily completed. M/s EFKON India Private Limited services (Design, supply, and installation & commissioning of Hardware, Software, Services etc.) met our expectations in terms of quality, performance and delivery. The system is performing satisfactorily from the date of its commissioning. The system is performing satisfactorily from date of its commissioning.

This Certificate is issued as per the request of EFKON India Pvt. Ltd. for the purpose of submitting as a testimonial for bids and does not have any commercial, contractual or legal binding on Tumakuru Smart City Limited (TSCL).

For Tumakuru Smart City Limited (TSCL),

*[Signature]*  
 Name: B T Rangaswamy K.M.A.S  
 Designation: Managing Director & Chief Executive Officer  
 Stamp



**TRUE COPY**  
*[Signature]*  
 Dilip N. Salve  
 ADVOCATE & NOTARY  
 238 #129, Murugesh, CHS, Kannamwar Nagar,  
 Tumakuru - 575 001, Karnataka, India





**Form EXP - 4.2(b): Specific Construction  
Experience in Key Activities**

Key Activity No. (1): Planning, designing, implementing and integration of traffic control center system comprising information gathering, processing and dissemination functions and human machine interface with following subsystems

**EFKON India Private Limited**

Project 6: DnD





EFKON INDIA PVT. LTD., 1115, 11th Floor, Rupa Solitaire, Building No. A-1 Sector 1, Millennium Business Park, Navi Mumbai, Mahape, Thane - 400710

**Form EXP – 4.2 (b)**  
**Specific Construction Experience in Key Activities**

Date: 08<sup>th</sup> December 2021

Bidder's Legal Name: JV of STRABAG Infrastructure & Safety Solutions GmbH and STRABAG AG

Subcontractor Party Legal Name: EFKON INDIA PRIVATE LIMITED

IFB No.: MMRDA/ENG1/0002561

Page 01 of 02 pages

**Key Activity No. (1):** Planning, designing, implementing and integration of traffic control center system comprising information gathering, processing and dissemination functions and human machine interface with following subsystems

- (a) Emergency Call Box system with at least 6 Nos. roadside terminals
- (b) Variable Message Signs System with at least 8 displays of 4 Mtr x 2 Mtr erected on the gantry
- (c) Traffic and security surveillance system consisting of at least 130 Nos. PTZ cameras
- (d) 2 Nos. installations of Automatic Traffic Counter and Classifier system for 3 lane projects
- (e) Supply and Installation of at least 3 three Meteorological Observation station
- (f) Supply and Installation of at least 130 Nos. Video Incident Detection Cameras for 3 lane projects;

Contract with Similar Key Activities			
Item	Information		
Contract Identification	Planning, Designing, Supply, implementing and integration for ATCC and VIDS		
Award Date	21 <sup>st</sup> February, 2015		
Completion Date	31 <sup>st</sup> October 2015		
Role in Contract	Prime Contractor		Management Contractor <input type="checkbox"/>
	Single entity <input checked="" type="checkbox"/>	JV member <input type="checkbox"/>	
Total Contract Amount	INR 12,20,00,000/-		1 INR = 0.0161 USD dated 22 <sup>nd</sup> September 2016 and total contract amount in USD equivalent is 1,963,467
Description of the Works undertaken for demonstration	Delhi NOIDA Direct Flyways Project is comprehensive Traffic Management Project providing Planning, designing, implementing and integration of traffic control center system comprising information		



Registered Office:

EFKON INDIA PVT. LTD.

1115, 11th Floor, Rupa Solitaire, Building No. A-1,

Sector 1, Millennium Business Park, Navi Mumbai

Mahape, Thane - 400710

CIN NO.: - U72900MH2001PTC132670

Tel. :+91 22 42949494

Fax :+91 22 42949333

Web.:http://www.efkonindia.com

**1601**





EFKON INDIA PVT. LTD., 1115, 11th Floor, Rupa Solitaire, Building No. A-1 Sector 1, Millennium Business Park, Navi Mumbai, Mahape, Thane - 400710

of the similarity of the key activity	gathering, processing and dissemination functions and human machine interface with following subsystems  (a) 51 Nos. installations of Automatic Traffic Counter and Classifier system covering 3 lane in each direction (b) Supply and Installation of 51 Nos. Video Incident Detection Cameras covering 3 lane in each direction
Employer's Name:	NOIDA Toll Bridge Company Ltd
Address:	Noida Toll Bridge Company limited, Toll plaza DND Flyway , NOIDA 201301
Telephone/Fax Number:	Phone: 0120-2516495 / Fax: 0120-2516440
E-mail:	ntbcl@ntbcl.com

- Attached is a true copy of the completion certificate or other similar document(s) for the contract / project issued by the client.

For EFKON India Private Limited,

Printed Name:  
Designation:

Gurpreet Singh Basra  
Lawful Attorney



Tarun Sharma  
Lawful Attorney



Registered Office:  
EFKON INDIA PVT. LTD.  
1115, 11th Floor, Rupa Solitaire, Building No. A-1,  
Sector 1, Millennium Business Park, Navi Mumbai  
Mahape, Thane - 400710  
CIN NO. : - U72900MH2001PTC132670

Tel. : +91 22 42949494  
Fax : +91 22 42949333  
Web.: <http://www.efkonindia.com>

1602

Form EXP - 4.2(b): Specific Construction  
Experience in Key Activities

Key Activity No. (1): Planning, designing, implementing and integration of traffic control center system comprising information gathering, processing and dissemination functions and human machine interface with following subsystems

**EFKON India Private Limited**

Project 6: DnD

True Copy of the Completion Certificate







**Noida  
Toll Bridge Co. Ltd.**



November 26, 2021

**TO WHOMSOEVER IT MAY CONCERN**

This to certify that M/s EF KON India Private Limited, having registered office at 1115, 11th Floor, Rupa Solitaire, Building No. A-1, Sector 1, Millennium Business Park, Mahape, Navi Mumbai 400710, has successfully executed a project against a contract with Noida Toll Bridge Company Ltd dated 21<sup>st</sup> February 2021, involving planning, designing, supply, implementing and integration of 51 Nos. of Video based Automatic for Traffic Counter & Classifier System & 51 Nos. Video Incident Detection system on Delhi-Noida Direct Flyway.

The overall project installation was completed on 31<sup>st</sup> Oct 2015

This Certificate is issued as per the request of EF KON India Private Limited for the purpose of submitting as a testimonia for bids and does not have any commercial, contractual or legal binding on Noida Toll Bridge Company Ltd

For Noida Toll Bridge Company Ltd

Authorized Signatory

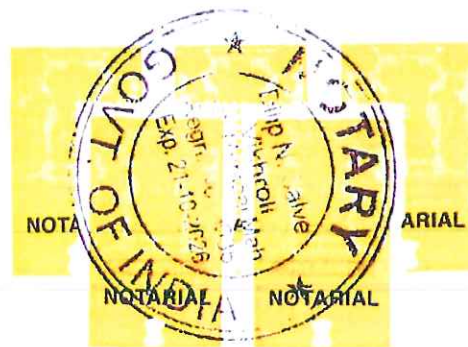

**TRUE COPY**

**Dip N. Salve**  
ADVOCATE & NOTARY

20/32, 1<sup>st</sup> Floor, DND Flyway, Noida-201 301, U.P. INDIA Phone: 0120 2515495  
11, Sector 18, Mayapuri, New Delhi-110028, India Phone: 011 26108831



Corporate Off: Toll Plaza, DND Flyway, Noida-201 301 U.P. INDIA Phone: 0120 2515495



Toll Plaza, Mayapuri Vihar Link Road, New Delhi - 110091 INDIA

Website: www.ntbc.com CIN: L45101DL1996PLC0315772

Form EXP - 4.2(b): Specific Construction  
Experience in Key Activities

**Key Activity No. (2): Design & Construction of Toll Management System for at least two projects, each having at least 8 Nos. toll gates (4 toll gates on each side; for two projects 16 Nos); Comprising of.**

**EFKON India Private Limited**

(a) Hybrid Lanes having Manual and ETC payment acceptance methods complete with all lane subsystems as per NHAI guidelines

(b) Toll plaza System with Hot standby Server installations, Backup devices,

(c) Central Toll Management System with Hot standby Server installations, Backup devices

(d) Data Communication System for lanes, TPS & TMS Software

(e) Closed Circuit Television for Toll Management System





Form EXP - 4.2(b): Specific Construction  
Experience in Key Activities

**Key Activity No. (2): Design & Construction of Toll Management System for at least two projects, each having at least 8 Nos. toll gates (4 toll gates on each side; for two projects 16 Nos); Comprising of.**

**EFKON India Private Limited**

Project 1: Hyderabad ORR TMS
Project 2: Gujarat Road And Infrastructure Company Limited (GRICL)
Project 3: Bangalore Elevated Tollway Pvt. Ltd (BETPL)
Project 4: Yamuna TMS
Project 5: PSEPL
Project 6: GVK Deolikota



**Form EXP - 4.2(b): Specific Construction  
Experience in Key Activities**

**Key Activity No. (2): Design & Construction of Toll Management System for at least two projects, each having at least 8 Nos. toll gates (4 toll gates on each side; for two projects 16 Nos); Comprising of.**

**EFKON India Private Limited**

**Project 1: Hyderabad ORR TMS**







EFKON INDIA PVT. LTD., 1115, 11th Floor, Rupa Solitaire, Building No. A-1 Sector 1, Millennium Business Park, Navi Mumbai, Mahape, Thane - 400710

**Form EXP – 4.2 (b)**  
**Specific Construction Experience in Key Activities**

Date: 08<sup>th</sup> December 2021

Bidder's Legal Name: JV of STRABAG Infrastructure & Safety Solutions GmbH and STRABAG AG

Subcontractor Party Legal Name: EFKON INDIA PRIVATE LIMITED

IFB No.: MMRDA/ENG1/0002561

Page 01 of 02 pages

**Key Activity No. (2):** Design & Construction of Toll Management System for at least two projects, each having at least 8 Nos. toll gates (4 toll gates on each side; for two projects 16 Nos); Comprising of.

- (a) Hybrid Lanes having Manual and ETC payment acceptance methods complete with all lane subsystems as per NHAI guidelines
- (b) Toll plaza System with Hot standby Server installations, Backup devices,
- (c) Central Toll Management System with Hot standby Server installations, Backup devices
- (d) Data Communication System for lanes, TPS & TMS Software
- (e) Closed Circuit Television for Toll Management System

Contract with Similar Key Activities			
Item	Information		
Contract Identification	Design, Supply, Installation, Commissioning, Testing and Warranty Maintenance for equipment's of Toll Collection System and Related Facilities for Outer Ring Road to Hyderabad City in the State of Telangana Contract No: CGM(T)/HGCL/TMS/2014-15 dated 18th December 2014		
Award Date	18 <sup>th</sup> December 2014		
Completion Date	12 <sup>th</sup> June 2020		
Role in Contract	Prime Contractor		Management Contractor <input type="checkbox"/>
	Single entity <input checked="" type="checkbox"/>	JV member <input type="checkbox"/>	
Total Contract Amount	INR 68,74,04,444/-		1 INR = 0.0159 USD dated 18 <sup>th</sup> December 2014 and total contract amount in USD equivalent is 10,911,095
Description of the Works undertaken for demonstration of the similarity of the key activity	<b>Hyderabad Growth Corridor Limited – Toll Management System comprising of following:</b> (a) Total no. of lanes - 181. (b) Hybrid Lanes having Manual and ETC payment acceptance methods complete with all lane subsystems,		



*[Handwritten signature]*



*[Handwritten signature]*



Registered Office:  
EFKON INDIA PVT. LTD.  
1115, 11th Floor, Rupa Solitaire, Building No. A-1,  
Sector 1, Millennium Business Park, Navi Mumbai  
Mahape, Thane - 400710  
CIN NO.: - U72900MH2001PTC132670

Tel. :+91 22 42949494  
Fax :+91 22 42949333  
Web.:http://www.efkonindia.com

**1608**

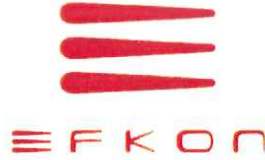

003639

EFKON INDIA PVT. LTD., 1115, 11th Floor, Rupa Solitaire, Building No. A-1 Sector 1, Millennium Business Park, Navi Mumbai, Mahape, Thane - 400710

	(c) Toll plaza System with Hot standby Server installations, Backup devices, (d) Central Toll Management System with Hot standby Server installations, Backup devices, (e) Data Communication System for lanes, TPS & TMS Software, (f) Closed Circuit Television for Toll Management System  Overall Hyderabad Growth Corridor Limited ORR Project also comprise of ATMS System involving: VMS, ECB, CCTV, VIDS, ATCC etc.
Employer's Name:	Hyderabad Growth Corridor Limited,
Address:	HGCL office building, 2nd floor, Nanakramguda, Hyderabad – 500 104
Telephone/Fax Number:	+91 - 40 – 27002913
E-mail:	cgmhgcl@gmail.com

Attached is a true copy of the completion certificate or other similar document(s) for the contract / project issued by the client.

For EFKON India Private Limited,

Gurpreet Singh Basra  
Lawful Attorney



Tarun Sharma  
Lawful Attorney

Printed Name:  
Designation:



Registered Office:  
EFKON INDIA PVT. LTD.  
1115, 11th Floor, Rupa Solitaire, Building No. A-1,  
Sector 1, Millennium Business Park, Navi Mumbai  
Mahape, Thane - 400710  
CIN NO. :- U72900MH2001PTC132670

Tel. :+91 22 42949494  
Fax :+91 22 42949333  
Web.:http://www.efkonindia.com

1609



**Form EXP - 4.2(b): Specific Construction  
Experience in Key Activities**

Key Activity No. (2): Design & Construction of Toll Management System for at least two projects, each having at least 8 Nos. toll gates (4 toll gates on each side; for two projects 16 Nos); Comprising of.

**EFKON India Private Limited**

**Project 1: Hyderabad ORR TMS**

**True Copy of the Completion Certificate**



# HYDERABAD GROWTH CORRIDOR LIMITED

Dated: 15<sup>th</sup> April, 2021

TO WHOMSOEVER IT MAY CONCERN

This to certify that M/s Efkon AG - M/s Efkon India Pvt. Ltd., having registered office at 1405-1408 SUPREMUS -E Wing, I Think Techno Campus, Kanjurmarg (East), Mumbai-400042, was awarded the work of "Design, Supply, Installation, Commissioning, Testing and Warranty Maintenance for equipment's of Toll Collection System and Related Facilities for Outer Ring Road to Hyderabad City in the State of Telangana" for Distance based Toll Management System for 19 toll plazas on "Outer Ring Road Hyderabad" for a Gross Contract value **Rs. 68,74,04,444/-**.

1. Contract Agreement No : CGM(T)/HGCL/TMS/2014-15, Dt. 18.12.2014
2. Actual Date of Completion for Manual & Touch & Go lanes : Dt.12.06.2018
3. Actual Date of Completion for RFID lanes (As part of Variation) : Dt.16.02.2019
4. DLP Period : 2 Years (12.06.2018 to 11.06.2020)
5. Project description executed under this Contract is as under:
  - i. Length of the stretch : 158 Km
  - ii. No of Plazas : 19 (08 Tunnel Plazas + 11 Ramp Plazas)
  - iii. Total no. of Lanes : 180 Lanes (Including 180 RFID ETC Lanes)
  - iv. Type of Tolling : Distance Based Tolling
  - v. CCTV Surveillance System with Video Analytics Comprising of 607 Cameras.
    - a) Video Incident Detection Cameras : 180 Nos
    - b) PTZ Surveillance Cameras : 58 Nos
    - c) Security Surveillance Cameras : 189 Nos
    - d) Dome Cameras : 180 Nos
  - vi. AVCC (Automatic Vehicle Counting and Classifier): - 180 Nos.
  - vii. Dedicated Optical Fiber Cable (OFC) - 12.5 Km Length.
6. Setting up and Management of IT Infrastructure for Tier III+ Compliant Data Centre for Plaza Computers at 19 Locations.
7. Efkon Command and control Centre - Main Traffic Control Centre (1 Nos), Sub Traffic Control Centre (1 Nos) and Toll Administrative Centers (19 Nos).

All the equipment supply, installation and Operation & Maintenance works under the contract has been satisfactorily completed. M/s EFKON Services (Hardware, Software, Services etc.) met our expectation in terms of quality, performance and delivery. The system is performing satisfactorily from date of its commissioning.

This certificate is being issued specifically for the purpose of submitting tender.

Date: 15<sup>th</sup> April, 2021  
Place: Hyderabad

**TRUE COPY**

**Dilip N. Salve**  
- ADVOCATE & NOTARY

238 9320 Manas CHS, Kannamwar Nagar  
No. 2 Vikhroli (E), Mumbai - 400 083

(Chief General Manager (Tech))  
HGCL





**Form EXP - 4.2(b): Specific Construction  
Experience in Key Activities**

**Key Activity No. (2): Design & Construction of Toll Management System for at least two projects, each having at least 8 Nos. toll gates (4 toll gates on each side; for two projects 16 Nos); Comprising of.**

**EFKON India Private Limited**

**Project 2: Gujarat Road And Infrastructure Company  
Limited (GRICL)**





EFKON INDIA PVT. LTD., 1115, 11th Floor, Rupa Solitaire, Building No. A-1 Sector 1, Millennium Business Park, Navi Mumbai, Mahape, Thane - 400710

**Form EXP – 4.2 (b)**  
**Specific Construction Experience in Key Activities**

Date: 08<sup>th</sup> December 2021

Bidder's Legal Name: JV of STRABAG Infrastructure & Safety Solutions GmbH and STRABAG AG

Subcontractor Party Legal Name: EFKON INDIA PRIVATE LIMITED

IFB No.: MMRDA/ENG1/0002561

Page 01 of 02 pages

**Key Activity No. (2):** Design & Construction of Toll Management System for at least two projects, each having at least 8 Nos. toll gates (4 toll gates on each side; for two projects 16 Nos); Comprising of.

- (a) Hybrid Lanes having Manual and ETC payment acceptance methods complete with all lane subsystems as per NHAI guidelines
- (b) Toll plaza System with Hot standby Server installations, Backup devices,
- (c) Central Toll Management System with Hot standby Server installations, Backup devices
- (d) Data Communication System for lanes, TPS & TMS Software
- (e) Closed Circuit Television for Toll Management System

Contract with Similar Key Activities			
Item	Information		
Contract Identification	Supply, Installation, Testing, Integration, Commissioning and Maintenance of Toll Management System (Hardware & Software) at Vadodara Halal Road Project (VHRP) & Ahmedabad Mehsana Road Project (AMRP).		
Award Date	21 <sup>st</sup> January 2019		
Completion Date	01 <sup>st</sup> April 2019		
Role in Contract	Prime Contractor		Management Contractor <input type="checkbox"/>
	Single entity <input checked="" type="checkbox"/>	JV member <input type="checkbox"/>	
Total Contract Amount	INR 5,55,35,676/-		1 INR = 0.0140 USD dated 21 <sup>st</sup> January 2019 and total contract amount in USD equivalent is 780,137
Description of the Works undertaken for demonstration of the similarity of the key activity	<b>GRICL – Toll Management System Project comprising of following:</b> (a) Total no. of lanes - 30. (b) Hybrid Lanes having Manual and ETC payment acceptance methods complete with all lane subsystems, (c) Toll plaza System with Hot standby Server installations, Backup devices,		



*[Handwritten signature]*



*[Handwritten signature]*



Registered Office:

EFKON INDIA PVT. LTD.

1115, 11th Floor, Rupa Solitaire, Building No. A-1,  
Sector 1, Millennium Business Park, Navi Mumbai  
Mahape, Thane - 400710

CIN NO.: - U72900MH2001PTC132670

Tel. :+91 22 42949494

Fax :+91 22 42949333

Web.:http://www.efkonindia.com

**1613**





EFKON INDIA PVT. LTD., 1115, 11th Floor, Rupa Solitaire, Building No. A-1 Sector 1, Millennium Business Park, Navi Mumbai, Mahape, Thane - 400710

	(d) Central Toll Management System with Hot standby Server installations, Backup devices, (e) Data Communication System for lanes, TPS & TMS Software, (f) Closed Circuit Television for Toll Management System
Employer's Name:	Gujarat Road and Infrastructure Company Limited (GRICL)
Address:	301, Shapath - 1, Opp. Rajpath Club, S.G. Highway, Bodakdev, Ahmedabad, 380015
Telephone/Fax Number:	+91 -79 26873413 / +91 - 79 - 79 26870094
E-mail:	info@gricl.in

- Attached is a true copy of the completion certificate or other similar document(s) for the contract / project issued by the client.

For EFKON India Private Limited,

Printed Name:  
Designation:

Gurpreet Singh Basra  
Lawful Attorney



Tarun Sharma  
Lawful Attorney



Registered Office:  
EFKON INDIA PVT. LTD.  
1115, 11th Floor, Rupa Solitaire, Building No. A-1,  
Sector 1, Millennium Business Park, Navi Mumbai  
Mahape, Thane - 400710  
CIN NO.: - U72900MH2001PTC132670

Tel. :+91 22 42949494  
Fax :+91 22 42949333  
Web.:http://www.efkonindia.com



**Form EXP - 4.2(b): Specific Construction  
Experience in Key Activities**

Key Activity No. (2): Design & Construction of Toll Management System for at least two projects, each having at least 8 Nos. toll gates (4 toll gates on each side; for two projects 16 Nos); Comprising of.

**EFKON India Private Limited**

**Project 2: Gujarat Road And Infrastructure Company  
Limited (GRICL)**

**True Copy of the Completion Certificate**







## GUJARAT ROAD AND INFRASTRUCTURE COMPANY LIMITED

301, Shapath - 1, Opp. Rajpath Club, S.G. Highway, Bodakdev, Ahmedabad 380015, Gujarat, India  
Phone : +91 79 26873413 • Fax : +91 79 26870094 • E-mail : info@gricl.in • CIN : U65990GJ1999PLC036086



### Completion Certificate

Date: 03<sup>rd</sup> December 2021

This to certify that M/s EFKON India Private Limited, having registered office at 1115, 11th Floor, Rupa Solitaire, Building No. A-1, Sector 1, Millennium Business Park, Mahape, Navi Mumbai 400710, was awarded the project of Toll Management System (Hardware & Software) at Vadodara Halal Road Project (VHRP) & Ahmedabad Mehsana Road Project (AMRP).

As a client, Gujarat Road and Infrastructure Company Limited, we confirm that entire supply of equipment, installation works under the contract has been satisfactorily completed. M/s EFKON India Private Limited services / support (Design, engineering, planning, supply, construction, development, installation, testing, integration, commissioning and maintenance, services etc.) met our expectations in terms of quality, performance and delivery. The system is performing satisfactorily from the date of its commissioning.

Project Title	Supply, Installation, Testing, Integration, Commissioning and Maintenance of Toll Management System (Hardware & Software) at Vadodara Halal Road Project (VHRP) & Ahmedabad Mehsana Road Project (AMRP).	
Purchase Order/Work Order ID / Contract Agreement	Work Order: GRICL-AMRP (Hardware/Software)/WO/TMS/ 2019/250 dated January 21, 2019 Amemdment PO: GRICL-AMRP (Hardware/Software)/WO/TMS/ 2019/250- Amendment 1 dated March 5 2019 Addendum: GRICL-AMRP (Hardware/Software)/WO/TMS/2020/83 October 10, 2020	Work Order: GRICL-VHRP (Hardware/Software)/WO/TMS/ 2019/251 dated January 21, 2019 Amemdment PO: GRICL-VHRP (Hardware/Software)/WO/TMS/2019/251- Amendment 1 dated March 5 2019 Addendum: GRICL-VHRP (Hardware/Software)/WO/TMS/2020/84 October 10, 2020
Place of Project	Ahmedabad Mehsana Road Project Gandhinagar Gujarat	Vadodara Halol Road Project Vadodara (Baroda) Gujarat
Project Owner	Government of Gujarat, Road & Building Department	
Type of Tolling	Distance based Tolling	Distance based Tolling
Total number of Plaza	4	4
Number of Hybrid ETC Lanes	15	15
Completion date (Go Live)	01-April-2019	01-April-2019
Project Value	21805708 + 7316835	20843842 + 5569291
O&M Duration Post Go Live	2+3 Years	2+3 Years



Registered Office: Office of The Secretary, Roads and Buildings Department, Block No. 14, Sachivalaya, Gandhinagar - 382 010 Gujarat





**Scope of work:**

Design, engineering, planning, supply, construction, development, installation, testing, integration, commissioning and maintenance comprising of:

1. Hybrid Lanes (Manual and ETC payment MOP) controlled through state of art lane controller units (LCU).
2. High performance Automatic Vehicle classification system (AVC).
3. Intelligent Toll booths: Keyboard & Monitor, Receipt Printer, Intercom Slave, Panic Switch, Outdoor Smartcard Reader, Desktop Smartcard Reader, Barcode Scanner, Biometric User Validation, Manual Booth Controller.
4. All lanes are equipped with components: Traffic light, User Fare Display, Violation alarm, RFID Transceiver, Overhead Lane Signal, Video Incident Capture Camera System, Automatic Number Plate Recognition System, Automatic Lane Barrier, Audio Communication System, Fog Lights and Surveillance system (CCTV) for Plaza and lanes.
5. Data Communication System (OFC based) for lanes and plaza.
6. Central Toll Plaza data center equipment at Admin building & Point of sale (POS) location: Toll Plaza Server in hot standby configuration, storage, Backup devices, Cash up Workstation, Admin Workstation, POS workstation.
7. Toll Management Software: Hybrid ETC Lane Software, Central Toll Management Software, Head quarter Management system, CCH Software module for Fastags, Cashup Software, Optical Character Recognition (OCR) Software, Audit & Reporting module, Lane Status Display System, Point of Sales Software.
8. Web-enabled Customer portal with on-line payment gateway.
9. Onsite 24x7 technical support

This Certificate is issued as per the request of EFKON India Private Limited for the purpose of submitting as a testimonial for bids and does not have any commercial, contractual or legal binding on Gujarat Road and Infrastructure Company Limited.

**Signature & Contact details:**

Name: PRAVEEN VASANTH

Title: CHIEF EXECUTIVE OFFICER

Project Name: Vadodara Halal Road Project (VHRP) & Ahmedabad Mehsana Road Project (AMRP)

Company: GUJARAT ROAD AND INFRASTRUCTURE CO. LTD

Date: 03<sup>rd</sup> December 2021

Signature:

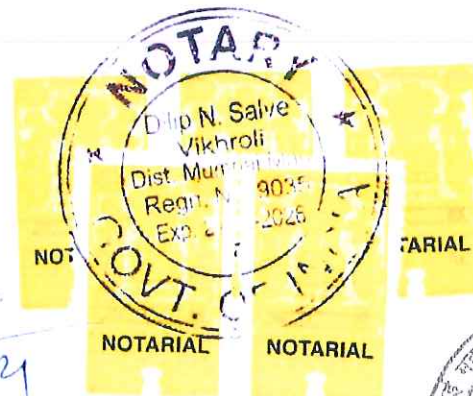

TRUE COPY

*Dilip N. Salve*  
Dilip N. Salve  
ADVOCATE & NOTARY

238 9120, Marak CHS, Kumbharwar Nagar  
No. 2, Vardh..., Mumbai...





**Form EXP - 4.2(b): Specific Construction  
Experience in Key Activities**

**Key Activity No. (2): Design & Construction of Toll Management System for at least two projects, each having at least 8 Nos. toll gates (4 toll gates on each side; for two projects 16 Nos); Comprising of.**

**EFKON India Private Limited**

**Project 3: Bangalore Elevated Tollway Pvt. Ltd (BETPL)**





EFKON INDIA PVT. LTD., 1115, 11th Floor, Rupa Solitaire, Building No. A-1 Sector 1, Millennium Business Park, Navi Mumbai, Mahape, Thane - 400710

**Form EXP – 4.2 (b)**  
**Specific Construction Experience in Key Activities**

Date: 08<sup>th</sup> December 2021

Bidder's Legal Name: JV of STRABAG Infrastructure & Safety Solutions GmbH and STRABAG AG

Subcontractor Party Legal Name: EFKON INDIA PRIVATE LIMITED

IFB No.: MMRDA/ENG1/0002561

Page 01 of 02 pages

**Key Activity No. (2):** Design & Construction of Toll Management System for at least two projects, each having at least 8 Nos. toll gates (4 toll gates on each side; for two projects 16 Nos); Comprising of.

- Hybrid Lanes having Manual and ETC payment acceptance methods complete with all lane subsystems as per NHAJ guidelines
- Toll plaza System with Hot standby Server installations, Backup devices,
- Central Toll Management System with Hot standby Server installations, Backup devices
- Data Communication System for lanes, TPS & TMS Software
- Closed Circuit Television for Toll Management System

Contract with Similar Key Activities			
Item	Information		
Contract Identification	Design, Supply, Upgradation/ Installation, Integration, Testing & Commissioning of Toll Collection and Management System, DLP for 2 years and Comprehensive AMC for 3 years at Bangalore Elevated Toll Road Project in the State of Karnataka. Contract Agreement Reference no. BETPL/Tech/2020-21/006		
Award Date	18 <sup>th</sup> December 2020		
Completion Date	01 <sup>st</sup> June 2021		
Role in Contract	Prime Contractor		Management Contractor <input type="checkbox"/>
	Single entity <input checked="" type="checkbox"/>	JV member <input type="checkbox"/>	
Total Contract Amount	INR 7,87,48,861/-		1 INR = 0.0136 USD dated 18 <sup>th</sup> December 2020 and total contract amount in USD equivalent is 1,070,755
Description of the Works undertaken for demonstration of the similarity of the key activity	BETPL – Toll Management System Project comprising of following: (a) Total no. of lanes - 49. (b) Hybrid Lanes having Manual and ETC payment acceptance methods complete with all lane subsystems,		



*[Handwritten Signature]*



*[Handwritten Signature]*



Registered Office:

EFKON INDIA PVT. LTD.

1115, 11th Floor, Rupa Solitaire, Building No. A-1,

Sector 1, Millennium Business Park, Navi Mumbai

Mahape, Thane - 400710

CIN NO.: - U72900MH2001PTC132670

Tel. :+91 22 42949494

Fax :+91 22 42949333

Web :http://www.efkonindia.com

**1619**





EFKON INDIA PVT. LTD., 1115, 11th Floor, Rupa Solitaire, Building No. A-1 Sector 1, Millennium Business Park, Navi Mumbai, Mahape, Thane - 400710

	(c) Toll plaza System with Hot standby Server installations, Backup devices, (d) Central Toll Management System with Hot standby Server installations, Backup devices, (e) Data Communication System for lanes, TPS & TMS Software, (f) Closed Circuit Television for Toll Management System
Employer's Name:	Bangalore Elevated Tollway Pvt. Ltd.
Address:	316-217, C Wing, kanakia Zillion, L.B.S. Road, BKC Annex, Kurla (W), Mumbai 400070
Telephone/Fax Number:	+91 - 22 61073200 / +91 - 22 61073201
E-mail:	

Attached is a true copy of the completion certificate or other similar document(s) for the contract / project issued by the client.

For EFKON India Private Limited,

Printed Name:  
Designation:

Gurpreet Singh Basra  
Lawful Attorney



Tarun Sharma  
Lawful Attorney



Registered Office:  
EFKON INDIA PVT. LTD.  
1115, 11th Floor, Rupa Solitaire, Building No. A-1,  
Sector 1, Millennium Business Park, Navi Mumbai  
Mahape, Thane - 400710  
CIN NO.: - U72900MH2001PTC132670

Tel. :+91 22 42949494  
Fax :+91 22 42949333  
Web :http://www.efkonindia.com



**Form EXP - 4.2(b): Specific Construction  
Experience in Key Activities**

**Key Activity No. (2): Design & Construction of Toll Management System for at least two projects, each having at least 8 Nos. toll gates (4 toll gates on each side; for two projects 16 Nos); Comprising of.**

**EFKON India Private Limited**

**Project 3: Bangalore Elevated Tollway Pvt. Ltd (BETPL)**

**True Copy of the Completion Certificate**





## BANGALORE ELEVATED TOLLWAY PRIVATE LIMITED

## Completion Certificate

Date: 09<sup>th</sup> December 2021

This is to certify that M/s EFKON India Private Limited, having registered office at 1115, 11th Floor, Rupa Solitaire, Building No. A-1, Sector 1, Millennium Business Park, Manape, Navi Mumbai 400710, was awarded the project of Toll Management System at Bangalore Elevated Toll Road Project in the State of Karnataka.

As a client, Bangalore Elevated Tollway Pvt. Ltd., we confirm that entire supply of equipment, installation works under the contract has been satisfactorily completed. M/s EFKON India Private Limited services / support (Design, engineering, planning, supply, construction, development, installation, testing, integration, commissioning and maintenance, services etc.) met our expectations in terms of quality, performance and delivery. The system is performing satisfactorily from the date of its commissioning.

Project Title	Design, Supply, Upgradation, Installation, Integration, Testing & Commissioning of Toll Collection and Management System, DLP for 2 years and Comprehensive AMC for 3 years at Bangalore Elevated Toll Road Project in the State of Karnataka.
Purchase Order / Work Order ID / Contract Agreement	Contract Agreement Reference no. BETPL/Tech/2020-21/006 Dated - 18 <sup>th</sup> December 2020
Place of Project	Bangalore
Project Owner	National Highways Authority of India (NHAI)
Type of Tolling	Close Loop Tolling
Total number of Plaza	5 Nos.
Number of Hybrid ETC Lanes	34 Hybrid ETC Lanes & 15 Two-wheeler Smart card Lanes
Completion date (Go Live)	01-06-2021
Project Value	INR 7.87.18.36L
O&M Duration Post Go Live	DLP for 2 years and Comprehensive AMC for 3 years



4

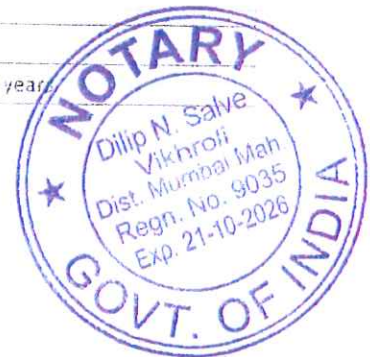

## Regd Office

316-317, C Wing, Kanakia Ziloon,  
L B S Road, BKC Annex, Kurla (W), Mumbai - 400 070  
Tel: +91 22 61073200 • Fax: +91 22 61073201  
CIN No: U45200MH2008PT 2296648  
Web: www.brelevated.com



## Site Office :

Main Base Camp, Near D-Mart,  
KIADB Road, Electronic City  
Phase-1, Bangalore - 560 100  
Tel: +91 80 28520758 • 28520760

# BANGALORE ELEVATED TOLLWAY PRIVATE LIMITED

### Scope of work.

Design, engineering, planning, supply, construction, development, installation, testing, integration, commissioning and maintenance comprising of:

1. Hybrid lanes (Manual and ETC payment MOP) controlled through state of art lane controller units (LCU)
2. High performance Automatic vehicle classification system (AVC)
3. Intelligent Toll booths: Keyboard & Monitor, Receipt Printer, Intercom Slave, Panic Switch, Outdoor Smartcard Reader, Desktop Smartcard Reader, Barcode Scanner, Biometric User validation, Manual Booth Controller
4. All lanes are equipped with components: Traffic light, User Fare Display, Violation alarm, RFID Transceiver, Overhead Lane Signal, Video Incident Capture Camera System, Automatic Number Plate Recognition System, Automatic Lane Barrier, Audio Communication System, Fog Lights and Surveillance system (CCTV) for Plaza and lanes
5. Data Communication System (OFC based) for lanes and plaza
6. Central Toll Plaza data center equipment at Admin building & Point of sale (POS) location: Toll Plaza Server in hot standby configuration, storage, Backup devices, Cash up Workstation, Admin Workstation, POS workstation.
7. Toll Management Software, Hybrid ETC Lane Software, Central Toll Management Software, Head quarter Management system, CCH Software module for Fastags, Cashup Software, Optical Character Recognition (OCR) Software, Audit & Reporting module, Lane Status Display System, Point of Sales Software
8. Web-enabled Customer portal with on-line payment gateway
9. WIM & SWB for weight measurement
10. Onsite 24x7 technical support

This Certificate is issued as per the request of EFKON India Private Limited for the purpose of submitting as a testimonial for bids and does not have any commercial, contractual or legal binding on Bangalore Elevated Tollway Pvt. Ltd.

*Biju Francis*

Signature & Contact details:

Name: Biju Francis

Title: Project Manager

Project Name: Bangalore Elevated Tollway Pvt Ltd

Company: Highway concessions

Date: 09<sup>th</sup> December 2021

Signature

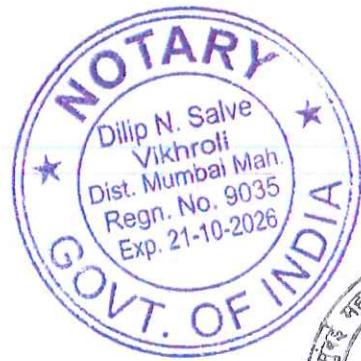

**TRUE COPY**  
*Dilip N. Salve*  
**Dilip N. Salve**  
ADVOCATE & NOTARY

238/9320, Manas CHS, Kannamwar Nagar  
No. 2, Vikhroli (E), Mumbai - 400072



NOTARIAL NOTARIAL NOTARIAL



**Form EXP - 4.2(b): Specific Construction  
Experience in Key Activities**

**Key Activity No. (2): Design & Construction of Toll Management System for at least two projects, each having at least 8 Nos. toll gates (4 toll gates on each side; for two projects 16 Nos); Comprising of.**

**EFKON India Private Limited**

**Project 4: Yamuna TMS**





EFKON INDIA PVT. LTD., 1115, 11th Floor, Rupa Solitaire, Building No. A-1 Sector 1, Millennium Business Park, Navi Mumbai, Mahape, Thane - 400710

**Form EXP – 4.2 (b)**  
**Specific Construction Experience in Key Activities**

Date: 08<sup>th</sup> December 2021

Bidder's Legal Name: JV of STRABAG Infrastructure & Safety Solutions GmbH and STRABAG AG

Subcontractor Party Legal Name: EFKON INDIA PRIVATE LIMITED

IFB No.: MMRDA/ENG1/0002561

Page 01 of 02 pages

**Key Activity No. (2):** Design & Construction of Toll Management System for at least two projects, each having at least 8 Nos. toll gates (4 toll gates on each side; for two projects 16 Nos); Comprising of.

- Hybrid Lanes having Manual and ETC payment acceptance methods complete with all lane subsystems as per NHAI guidelines
- Toll plaza System with Hot standby Server installations, Backup devices,
- Central Toll Management System with Hot standby Server installations, Backup devices
- Data Communication System for lanes, TPS & TMS Software
- Closed Circuit Television for Toll Management System

Contract with Similar Key Activities			
Item	Information		
Contract Identification	Yamuna Expressway – Toll Management System Contract Agreement Reference no. JAL/YEP/CP-1/2/3/2385, JAL/YEP/CP-1/2/3/3110		
Award Date	08 <sup>th</sup> November, 2011		
Completion Date	09 <sup>th</sup> August 2012 (Go Live)		
Role in Contract	Prime Contractor		Management Contractor <input type="checkbox"/>
	Single entity <input checked="" type="checkbox"/>	JV member <input type="checkbox"/>	
Total Contract Amount	INR 13,29,86,549/-		1 INR = 0.0150 USD dated 08 <sup>th</sup> November, 2011 and total contract amount in USD equivalent is 2,692,035
Description of the Works undertaken for demonstration of the similarity of the key activity	Yamuna Expressway – Toll Management System comprising of following: (a) Total no. of lanes - 96. (b) Hybrid Lanes having Manual and ETC payment acceptance methods complete with all lane subsystems, (c) Toll plaza System with Hot standby Server installations, Backup devices,		



Registered Office:

EFKON INDIA PVT. LTD.

1115, 11th Floor, Rupa Solitaire, Building No. A-1,  
Sector 1, Millennium Business Park, Navi Mumbai  
Mahape, Thane - 400710

CIN NO.: - U72900MH2001PTC132670



Tel. :+91 22 42949494

Fax :+91 22 42949333

Web.:http://www.efkonindia.com



1625





003656

EFKON INDIA PVT. LTD., 1115, 11th Floor, Rupa Solitaire, Building No. A-1 Sector 1, Millennium Business Park, Navi Mumbai, Mahape, Thane - 400710

	(d) Central Toll Management System with Hot standby Server installations, Backup devices (e) Data Communication System for lanes, TPS & TMS Software, (f) Closed Circuit Television for Toll Management System  Overall Yamuna Expressway Project also comprise of ATMS System involving: VMS, ECB, CCTV, VIDS, Speed Enforcement, ANPR, Echallan etc.
Employer's Name:	Jaiprakash Associates Limited
Address:	Sector- 128, Noida- 201304, Uttar Pradesh
Telephone/Fax Number:	Ph No: (120) 4609000, 2470800 / Fax: (120) 4609464, 4609496
E-mail:	santosh.pawar@jalindia.co.in

Attached is a true copy of the completion certificate or other similar document(s) for the contract / project issued by the client.

For EFKON India Private Limited,

Printed Name:  
Designation:

Gurpreet Singh Basra  
Lawful Attorney



Tarun Sharma  
Lawful Attorney



Registered Office:  
EFKON INDIA PVT. LTD.  
1115, 11th Floor, Rupa Solitaire, Building No. A-1,  
Sector 1, Millennium Business Park, Navi Mumbai  
Mahape, Thane - 400710  
CIN NO.: - U72900MH2001PTC132670

Tel. :+91 22 42949494  
Fax :+91 22 42949333  
Web.:http://www.efkonindia.com



1626

Form EXP - 4.2(b): Specific Construction  
Experience in Key Activities

Key Activity No. (2): Design & Construction of Toll Management System for at least two projects, each having at least 8 Nos. toll gates (4 toll gates on each side; for two projects 16 Nos); Comprising of.

**EFKON India Private Limited**

Project 4: Yamuna TMS

True Copy of the Completion Certificate





# JAIPRAKASH ASSOCIATES LIMITED

Dated: 10.05.2017

## TO WHOMSOEVER IT MAY CONCERN

This to certify that M/s Efkon India Pvt. Ltd., having registered office at Om Sadan - Ground Floor, Mehra Industrial Estate, L.B.S Marg, Vikhroli (West), Mumbai, has been awarded the work of 'Supply of Indigenous Equipment for Toll System for Yamuna Expressway' vide Letter of Acceptance no. JAL/YEP/CP-1/2/3/2385 dated 08.11.2011 for a gross Contract value Rs.14,67,92,574.00 and additional work of Indigenous Equipment, PA System & Additional Indoor Plaza Building Camera entrusted vide Variation Order no. JAL/YEP/CP-1/2/3/3110 dated 17.01.2012 for a gross Contract value Rs.1,48,47,205.00 with date of commencement of work as 08.11.2011. The work is in progress but they have substantially completed the work to the tune of Rs 13,16,96,278.00 and Rs.12,90,271.00 respectively till 05.10.2012 to our satisfaction

Major items executed under this Contract are as under:

1. Lane area work including Toll Booth, User Fair Display (UFD) for Toll Lane, AVC Lane, Lane Communication, SSWIM, Queue Length Monitoring System.
2. Plaza Aread including Plaza Computer System, PA System, Network Equipment, Intercom Supply.
3. DVR & Plaza CC TV including Plaza DVR, Plaza Camera, Cables and Ancil ary items.
4. Spares including Toll Booth spare, AVC Lane spares & Plaza spares
5. POS & Cashup including POS coumpute system, Cashup System, Administration system, Network Equipment
6. Media Supply excluding Smart Card for Toll Collector Access to Lanes.
7. Test Rig including Toll Booth Test Rig, Toll Lane Test Rig, ETC Lane Test Rig, AVC Lane Test Rig.
8. Plaza Intercom system.
9. Tools and Test Equipment.
10. Cables and Cable containment system
11. Software / Licences including in House Software Application, Third Party Software but excluding Headquarter Monitoring System Licence

ATTESTED TO BE TRUE COPY

JOGINDER SINGH  
ADVOCATE & NOTARY  
GURUGRAM DISTT. (HR.)

This certificate is being issued on the specific request of the Contractor for the purpose of submitting tender only

For Jaiprakash Associates Limited

[Sunil Kumar Verma]  
Authorized Signatory



**JAYPEE**  
GROUP



Corp & Regd. Sector - 128, Noida - 201 304, Uttar Pradesh (India)  
Office : Ph. : +91 (120) 4609000, 2470800 Fax : +91 (0120) 4609464, 4609496  
Head Office : House, 63 Basant Lok, Vasant Vihar, New Delhi - 110 057 (India)  
Ph. : +91 (11) 26141540, 26147411 Fax : +91 (11) 26145389, 26143591  
Website : www.jalindia.co.in CIN : LI4106JP1995PLC19017

To Whom It May Concern

We hereby certify that M/S Efkon India Pvt. Ltd was awarded the contract of Design, supply, Installation for Electronic Collection System for the Yamuna Expressway Project.

- Name of Project: **Yamuna Expressway Ltd**
- Date of Award: **08-Nov-2011**
- Project Value: **INR 252,344,060.00**
- Date of Completion: **09-Aug-13**
- No of Plaza: **03 Number (JTP, MTP,ATP)**
- **Total 96 lanes comprising of the following**
  - a. Number of ETC RFID Based lanes: **96**
  - b. Number of Cash and Smart Card Lanes: **96**

Efkon India has supplied ETC RFID based toll system for all 96 lanes, along with semi automatic toll collections systems (Cash and Smart Card).

The project was commissioned on 09-Aug-12. The performance of the Toll collection System is meeting our requirements and is working to our satisfaction.

For Jaypee Infatech Ltd



Officially signed by

Name: *Devendra Padan*

Designation: *Vice President*



**JAYPEE INFRA TECH LIMITED**

Regd. Office : Sector - 128, Noida - 201304, Uttar Pradesh (India)  
 Ph: +91 (0120) 2470800 Fax: +91 (0120) 2470887 Website: www.jalindia.com





Form EXP - 4.2(b): Specific Construction  
Experience in Key Activities

Key Activity No. (2): Design & Construction of Toll Management System for at least two projects, each having at least 8 Nos. toll gates (4 toll gates on each side; for two projects 16 Nos); Comprising of.

**EFKON India Private Limited**

Project 5: PSEPL





EFKON INDIA PVT. LTD., 1115, 11th Floor, Rupa Solitaire, Building No. A-1 Sector 1, Millennium Business Park, Navi Mumbai, Mahape, Thane - 400710

**Form EXP – 4.2 (b)**  
**Specific Construction Experience in Key Activities**

Date: 08<sup>th</sup> December 2021

Bidder's Legal Name: JV of STRABAG Infrastructure & Safety Solutions GmbH and STRABAG AG

Subcontractor Party Legal Name: EFKON INDIA PRIVATE LIMITED

IFB No.: MMRDA/ENG1/0002561

Page 01 of 02 pages

**Key Activity No. (2):** Design & Construction of Toll Management System for at least two projects, each having at least 8 Nos. toll gates (4 toll gates on each side; for two projects 16 Nos); Comprising of.

- (a) Hybrid Lanes having Manual and ETC payment acceptance methods complete with all lane subsystems as per NHAI guidelines
- (b) Toll plaza System with Hot standby Server installations, Backup devices,
- (c) Central Toll Management System with Hot standby Server installations, Backup devices
- (d) Data Communication System for lanes, TPS & TMS Software
- (e) Closed Circuit Television for Toll Management System

Contract with Similar Key Activities			
Item	Information		
Contract Identification	Supply, Installation and Commissioning of Toll System Contract Agreement Reference no. PSEPL/CBA/2021-2013		
Award Date	03 <sup>rd</sup> February 2012		
Completion Date	December 2013		
Role in Contract	Prime Contractor		Management Contractor <input type="checkbox"/>
	Single entity <input checked="" type="checkbox"/>	JV member <input type="checkbox"/>	
Total Contract Amount	INR 13,88,99,478/-		1 INR = 0.0181 USD dated 03 <sup>rd</sup> February 2012 and total contract amount in USD equivalent is 2,854,783
Description of the Works undertaken for demonstration of the similarity of the key activity	PSEPL – Toll Management System comprising of following: (a) Total no. of lanes - 27. (b) Hybrid Lanes having Manual and ETC payment acceptance methods complete with all lane subsystems, (c) Toll plaza System with Hot standby Server installations, Backup devices, (d) Central Toll Management System with Hot standby Server installations, Backup devices,		



Registered Office:  
EFKON INDIA PVT. LTD.  
1115, 11th Floor, Rupa Solitaire, Building No. A-1,  
Sector 1, Millennium Business Park, Navi Mumbai  
Mahape, Thane - 400710  
CIN NO. : - U72900MH2001PTC132670

Tel. : +91 22 42949494

Fax : +91 22 42949333

Web : <http://www.efkonindia.com>

1631





EFKON INDIA PVT. LTD., 1115, 11th Floor, Rupa Solitaire, Building No. A-1 Sector 1, Millennium Business Park, Navi Mumbai, Mahape, Thane - 400710

	(e) Data Communication System for lanes, TPS & TMS Software (f) Closed Circuit Television for Toll Management System  Overall PSEPL Project also comprise of ATMS System involving: ECB, CCTV, VIDS, MET, AVC etc.
Employer's Name:	Pune Solapur Expressways Private Limited
Address:	Patas Plaza, KM65, NH 65 (OLD NH 9), Daund, District – Pune, Maharashtra - 412219
Telephone/Fax Number:	+91 – 211 7251111
E-mail:	

- Attached is a true copy of the completion certificate or other similar document(s) for the contract / project issued by the client.

For EFKON India Private Limited,

Printed Name:  
Designation:

  
Gurpreet Singh Basra  
Lawful Attorney



  
Tarun Sharma  
Lawful Attorney



Registered Office:  
EFKON INDIA PVT. LTD.  
1115, 11th Floor, Rupa Solitaire, Building No. A-1,  
Sector 1, Millennium Business Park, Navi Mumbai  
Mahape, Thane - 400710  
CIN NO.: - U72900MH2001PTC132670

Tel. :+91 22 42949494  
Fax :+91 22 42949333  
Web.:http://www.efkonindia.com



1632

Form EXP - 4.2(b): Specific Construction  
Experience in Key Activities

Key Activity No. (2): Design & Construction of Toll Management System for at least two projects, each having at least 8 Nos. toll gates (4 toll gates on each side; for two projects 16 Nos); Comprising of.

**EFKON India Private Limited**

Project 5: PSEPL

True Copy of the Completion Certificate







# PUNE SOLAPUR EXPRESSWAYS PRIVATE LIMITED

## Completion Certificate

Date: 12<sup>th</sup> July 2018

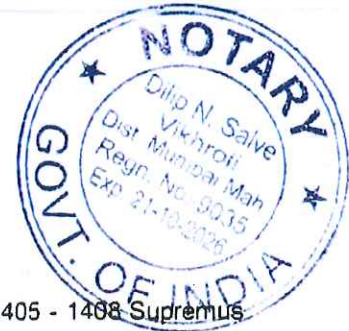

This is to certify that M/s. Eikon India Private Limited, its address being 1405 - 1408 Supremus E' - Wing, I Think Techno Campus, Kanjurmarg East, Mumbai 400 042, has been awarded for the Supply, Installation, System Integration Testing, Commissioning of Toll Collection and Management System at **Pune Solapur Expressways Private Limited**.

Implementation of the same has been successfully implemented and is running to full operational capacity.

Project Title	Supply Installation and Commissioning of Toll System
Purchase Order/Work Order ID	PSEPL/CBA/2012-2013
Place of Project	Pune-Solapur section of NH-9 from Km 40 000 to Km 150 050 in the state of Maharashtra
Type of Project	SITC with O&M
Total number of TMS Lanes	27 Lanes
Number of Cash Lanes	27 Lanes
Number of Hybrid ETC Lanes	4 Lanes
Number of Dedicated ETC Lanes	4 Lanes
Number of WIMs	10 Sets
Number of AVCC	26 Nos
Employer	Pune Solapur Expressways Private Limited
Implementation date	Aug 2013
Completion date	
System O&M period yr 1	2013-14
System O&M period yr 2	2014-15
System O&M period yr 3	2015-16

Scope of work:



1 Supply, Installation, Testing, commissioning and Maintenance of Electronic Toll Management System comprising of:

- A Lanes controlled through state of art lane controller units (LCU)
- B High performance Automatic Vehicle classification system(AVC)
- C Intelligent Toll booths Keyboard & Monitor, Receipt Printer, Intercom Slave, Panic Switch, Barcode Scanner, Manual Booth Controller.
- D Lanes are equipped with components. Traffic light, User Fare Display, Overhead Lane Signal, Violation alarm, RFID Transceiver, Overhead Lane Signal.
- E Toll plaza equipment's at Admin building & Point of sale (POS) location: Toll Plaza Server System, Cashup Workstation, Admin Workstation, POS workstation.
- F. Toll software's like Lane Software, Toll Management Software, Cashup Software, Audit & Reporting module, Lane Status Display System, Point of Sales Functionality
- G Web-enabled Customer portal including on-line payment gateway

With best regards,

Col. Vinay Ashish John Singh (Retd.)  
Chief Executive Officer

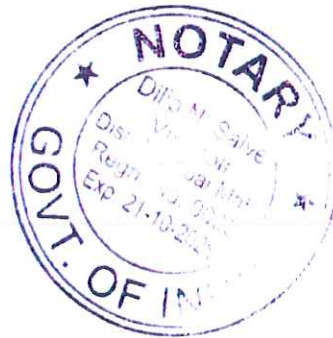





Document name: PSEPL / Toll / Hybrid-ETC/ SATP / 001 / V1 / R1





Revision matrix:

Rev. No.	Rev. Description	Auth. By	Date
	Initial version		17.02.2020
R0	R1 Included test cases for CCH transaction review & RFID HHT reader	DTM	04.07.2020



Design Process Owner  
Dip N. Salve | 9820172010



Approved by  
Classification: External



Design Team Manager  
Dip N. Salve





Table of Contents

1 Introduction ..... 4

2 Test Plan ..... 4

3 Executive Summary ..... 4

4 Inventory and Specifications Compliance ..... 5

5 Lane Level Equipment ..... 6

5.1 ETC Verification ..... 6

5.1.1 RFID Transceiver ..... 6

5.1.2 ETC Transaction Data Management ..... 7

5.1.3 Pass Back Timer ..... 7

5.1.4 Software Security ..... 8

5.1.5 Throughput & Performance ..... 8

5.2 Hybrid ETC Lane Functionality ..... 8

5.3 Operations ..... 9

5.4 Other Equipment ..... 10

5.5 Surveillance System at Lane ..... 12

5.6 RFID HHT ..... 12

6 Plaza Level Equipment ..... 13

6.1 Wiring and Installation Standards ..... 13

6.2 Reports Available at Toll Plaza Server ..... 14

6.3 Lane Communication System ..... 14

6.4 CCH Transaction Review ..... 15

7 Conclusion ..... 21



Prepared by

Design Process Owner

Approved by

Design Team Manager

Format No: SJ&E/DE&D-F7/V1/R0

Classification: External

3 of 21





**1 Introduction**

This document contains a list of tests to be performed for the site acceptance of the Hybrid ETC lanes in the PSEPL project

**2 Test Plan**

Interpretation of "Status" field

Sr.	Status	Interpretation
1.	OK	Functional and as per specifications
2.	NOT OK	Need correction, system cannot work
3.	IMP	Need correction but system functional

Table 2.1 – Interpretation of "Status" Field

**3 Executive Summary**

Sr.	Status	Interpretation
A.	Date of trial	20/10/2020 to 22/10/2020
B.	Plaza details	Indapur plaza
a.	Plaza name	Indapur plaza
b.	Highway location (NH)	NH-9
c.	Plaza location (Chainage)	PATA & Indapur plaza
d.	Concessionaire/ toll operation agency	Pune Solapur Expressway Private Limited (PSEPL)
e.	PIU	PUNE (Project Director Unit)
f.	Plaza ID in CCH	PSPTS

Table 3.1 – Executive Summary



Prepared by

Design Process Owner

Approved by

Design Team Manager

Format No. 3D&E-DEL&OP-V1/R1

Application: External

4 of 21







4 Inventory and Specifications Compliance

Lane Number ID

Sr. No.	Item/ Description	Unit	Qty Available	Status (OK /Not OK/IMP)	Remarks
1)	RFID ETC transceiver near pay axis mounted on a pole	No	1 per lane	OK	
2)	AVC including sensors, loop and detector	Set	1 per lane	OK	
3)	Automatic Barrier Gate	No	1 per lane	OK	
4)	Loops with detector	No	1 per lane	OK	
5)	License Plate Image Capture Camera with mounting poles	Set	1 per lane	OK	
6)	Customized industrial grade keyboard	No	1 per lane	OK	
7)	Violation light & Alarm (on existing pole) and Foot switch in booth	No	1 per lane	OK	
8)	Software-Lane Level	No	1 per lane	OK	
9)	Intercom Slave unit in booth	No	1 per lane	OK	
10)	8 Port Network switch (POE-based)	No	1 per Lane	OK	
11)	Software-Plaza level	No	1 per plaza	OK	
12)	Intercom Master Unit in Control Room- 20 Channel (For >8 lanes)	No	1 per plaza	OK	



Project Director  
Mumbai Metro Rail & Tram

Design Process Owner

Approved by

Qualification: Engineer



Design Team Manager









EFKON INDIA PVT. LTD  
 Site Acceptance Test Procedure (SATP)  
 PSEPL/PL - Full /Hybad-ETC / SATP / 001 / V1 / R1

7 Conclusion

Above tests were conducted successfully. The observations are recorded as above

Signature: 	Signature: 
For PSEPL 	For M/s <b>EFKON INDIA PVT. LTD.</b> 
Name: <u>Mukhtiar Bhatti</u>	Name: <u>Jeevan Kumpkar</u>

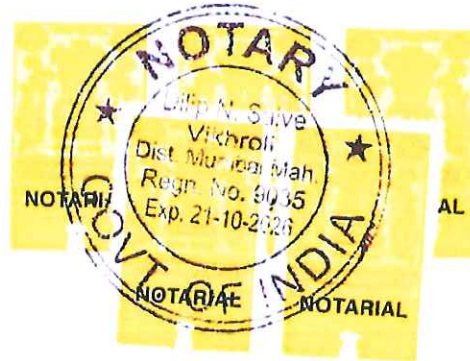

TRUE COPY

  
 Dilip N. Salve

ADVOCATE & NOTARY

218 9320, Manas CHS, Khandivkar Nagar  
 No. 2, Vikhroli (E), Mumbai - 400 083



Prepared by

Design Process Owner

Approved by

Design Team Manager

Form No. ETK-001 & ETK-002

Location: Hyderabad

Date: 11/11/22







**PUNE SOLAPUR EXPRESSWAYS PRIVATE LIMITED**

Toll Plaza Building Patas, KM 65 NH 65, Village Patas, At Post Patas, Taluka Daund, District Pune, Maharashtra - 412219

**PROJECT NAME:**

**Pune Solapur Expressway Advance Traffic Management System & Toll Collection and Management System.**

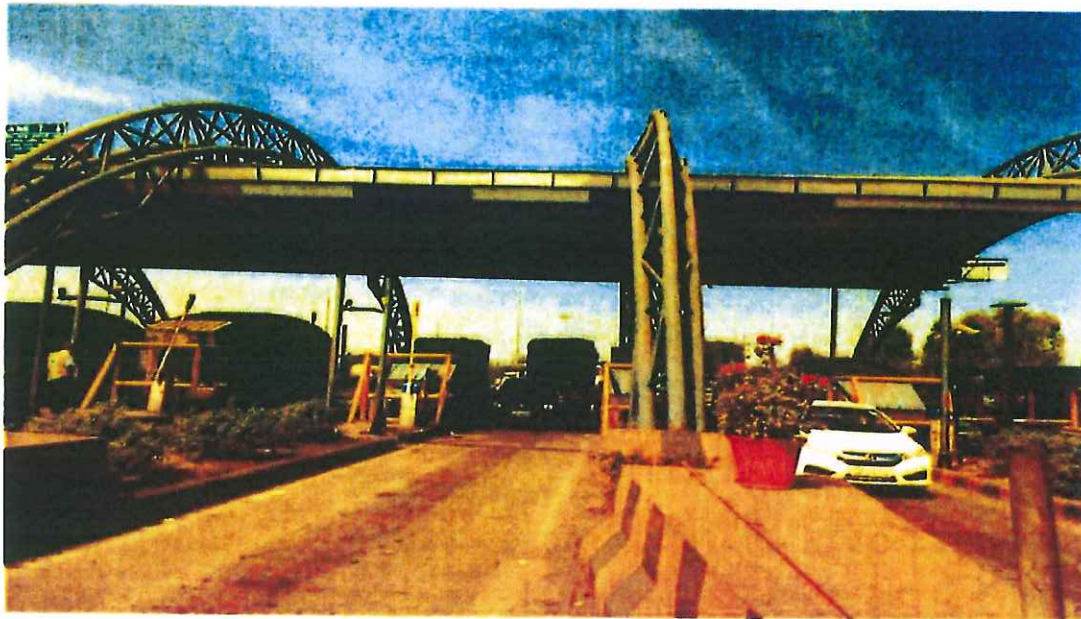

**CUSTOMER:**

Pune Solapur Expressway private limited

**PROJECT DATA:**

Stretch length of 104 Km is part of NH-9 connecting Pune to Solapur having total of 27 toll lanes and 2 toll plazas

**CONTRACT VALUE:**

Total contract value & AMC, Running operation cost – INR 13,88,99,478/-

**PROJECT PERIOD:**

Date of start: - 03.02.2012  
The Project is in operations since its completion in 2013 and the O&M period shall continue till 2021.

**PROJECT DESCRIPTION:**

Development, supply, installing, testing and commissioning operation and maintenance of Toll Collection and Management System & Advanced Traffic Management System for Pune - Solapur Expressway Private Limited from Yavat to Indapur

**GENERAL DATA:**

**HTMS EQUIPMENTS: -**

Regd Office Toll Plaza Building Patas, KM 65 NH 65, Village Patas, At Post Patas, Taluka Daund, District Pune

© 2013 STRABAG INFRASTRUCTURE & SAFETY SOLUTIONS GMBH. ALL RIGHTS RESERVED. 20DL2004FC148631





## PUNE SOLAPUR EXPRESSWAYS PRIVATE LIMITED

Toll Plaza Building Paras, KM 65 NH 65 Village Paras, At Post Paras, Taluka Daund, District Pune, Maharashtra - 412219

1. Emergency Telephone System – Emergency Call Box (ECB) – 55 Nos
2. Environment Monitoring System – Metrology Data System – (MDS) – 01 No.
3. CCTV (Closed Circuit Television) Surveillance System with VMS Licenses – 12 Nos.
4. Video Wall System for Traffic Monitoring in Command & Control Room.
5. Dedicated Optical Fiber Cable – 104 KM
6. Command & Control software, Integrating all above ITMS peripheral sensors system in the control room.

### Toll Management Equipment: -

1. Total Lane at Toll Plaza- 27 Nos
  - i. 4 - Nos Dedicated ETC Lane.
  - ii. 23 - Nos Smart Card/Barcode/Cash Lane
2. Lanes controlled through state of art lane controller units (LCU) – 27 nos. which control barriers, traffic lights, lane signals and overhear lane signals.
3. High performance Automatic Vehicle Classification system (AVC) with 97% accuracy – 27 nos.
4. Camera system on lane and Plaza: -
  - i. Enforcement camera with VMS – 30 nos.
  - ii. Traffic Monitoring camera with VMS – 30 nos
  - iii. Dome camera (booth cameras) with VMS – 30 nos
5. Intelligent Toll Booths equipped with following customize hardware: -
  - i. Keyboard and Monitor – 27 nos.
  - ii. Receipt printers – 27 nos.
  - iii. Intercom slave – 27 nos.
  - iv. Panic switch – 27 nos.
  - v. Barcode scanner – 27 nos.
  - vi. Manual booth controller – 27 nos.
6. Lanes are equipped with following components: -
  - i. Traffic light – 27 nos.
  - ii. User fare display – 27 nos.
  - iii. Overhead lane signal – 27 nos
  - iv. Violation alarms – 27 nos
  - v. RFID Trans receiver – 04 nos.
7. Toll Plaza equipment at Admin building and Point of Sale (POS) location include the following -
  - i. Toll Plaza Server System – 04 nos.
  - ii. Cash-up Workstation – 02 nos.
  - iii. Admin Workstation – 02 nos
  - iv. POS Workstation – 02 nos.







## PUNE SOLAPUR EXPRESSWAYS PRIVATE LIMITED

Toll Plaza Building Paras, KM 64 NH 65 Village Paras, At Post Paras, Taluka Dahanu, District Pune, Maharashtra - 412219

8. Toll Software include the followings: -
- i. Lane software – 27 nos.
  - ii. Toll Management Software – 02 nos.
  - iii. Cash-up Software – 02 nos.
  - iv. Audit and report model – 02 nos.
  - v. Lane Status Display System – 02 nos.
  - vi. Point of Sale functionality – 02 nos.
  - vii. Toll Management Software including video management system license for CCTV camera – 01 set.

We, Pune Solapur Expressway private limited confirms that work execution by EFKON India Private Limited is exceptional. M/s. EFKON India Private Limited, executed work professionally, punctually and in conformity with law with conforming to quality and safety requirements as per industry standards. We recommend EFKON INDIA Pvt Ltd as a willing partner for all future endeavors.

With best regards,

**Col. Vinay Ashish John Singh (Retd)**  
Chief Executive Officer



ATTESTED TO BE TRUE COPY  
**JOGINDER SINGH**  
ADVOCATE & NOTARY  
GURUGRAM DISTT. (HR.)  
26 NOV 2021



Regd. Office: Toll Plaza Building Paras, KM 65 NH 65 Village Paras, At Post Paras, Taluka Dahanu, District Pune, Maharashtra - 412219

Corporate Identification Number: U20002900070158611



Form EXP - 4.2(b): Specific Construction  
Experience in Key Activities

Key Activity No. (2): Design & Construction of Toll Management System for at least two projects, each having at least 8 Nos. toll gates (4 toll gates on each side; for two projects 16 Nos); Comprising of.

**EFKON India Private Limited**

Project 6: GVK Deolikota







EFKON INDIA PVT. LTD., 1115, 11th Floor, Rupa Solitaire, Building No. A-1 Sector 1, Millennium Business Park, Navi Mumbai, Mahape, Thane - 400710

**Form EXP – 4.2 (b)**  
**Specific Construction Experience in Key Activities**

Date: 08<sup>th</sup> December 2021

Bidder's Legal Name: JV of STRABAG Infrastructure & Safety Solutions GmbH and STRABAG AG

Subcontractor Party Legal Name: EFKON INDIA PRIVATE LIMITED

IFB No.: **MMRDA/ENG1/0002561**

Page 01 of 02 pages

**Key Activity No. (2):** Design & Construction of Toll Management System for at least two projects, each having at least 8 Nos. toll gates (4 toll gates on each side; for two projects 16 Nos); Comprising of.

- Hybrid Lanes having Manual and ETC payment acceptance methods complete with all lane subsystems as per NHAI guidelines
- Toll plaza System with Hot standby Server installations, Backup devices,
- Central Toll Management System with Hot standby Server installations, Backup devices
- Data Communication System for lanes, TPS & TMS Software
- Closed Circuit Television for Toll Management System

Contract with Similar Key Activities			
Item	Information		
Contract Identification	Design, Supply, Installation, Commissioning & Maintenance of Toll Management System Contract Agreement Reference no. GVK/Deoli Kota Expressway/TMS/CA No. 001		
Award Date	28 <sup>th</sup> June 2013		
Completion Date	31 <sup>st</sup> June 2015		
Role in Contract	Prime Contractor		Management Contractor <input type="checkbox"/>
	Single entity <input checked="" type="checkbox"/>	JV member <input type="checkbox"/>	
Total Contract Amount	INR 2,52,49,938/-		1 INR = 0.0167 USD dated 28 <sup>th</sup> June 2013 and total contract amount in USD equivalent is 424,378
Description of the Works undertaken for demonstration of the similarity of the key activity	GVK Deoli Kota Expressway – Toll Management System Project comprising of following: (a) Total no. of lanes - 12. (b) Hybrid Lanes having Manual and ETC payment acceptance methods complete with all lane subsystems, (c) Toll plaza System with Hot standby Server installations, Backup devices,		



*[Handwritten Signature]*



Registered Office:

EFKON INDIA PVT. LTD.  
1115, 11th Floor, Rupa Solitaire, Building No. A-1,  
Sector 1, Millennium Business Park, Navi Mumbai  
Mahape, Thane - 400710

CIN NO.: - U72900MH2001PTC132670

Tel. :+91 22 42949494

Fax :+91 22 42949333

Web: <http://www.efkonindia.com>

**1646**



EFKON INDIA PVT. LTD., 1115, 11th Floor, Rupa Solitaire, Building No. A-1 Sector 1, Millennium Business Park, Navi Mumbai, Mahape, Thane - 400710

	(d) Central Toll Management System with Hot standby Server installations, Backup devices, (e) Data Communication System for lanes, TPS & TMS Software, (f) Closed Circuit Television for Toll Management System
Employer's Name:	GVK Deoli Kota Expressway Pvt Ltd.
Address:	Kishorpura Toll Plaza, KM – 180, NH -12, Near PENCH KI BAORI, Tehsil – Hindoli, BUNDI – 323025, Rajasthan
Telephone/Fax Number:	+91 – 86969 79111
E-mail:	

- Attached is a true copy of the completion certificate or other similar document(s) for the contract / project issued by the client.

For EFKON India Private Limited,

Printed Name:  
Designation:

Gurpreet Singh Basra  
Lawful Attorney



Tarun Sharma  
Lawful Attorney

*Tarun Sharma*



Registered Office:  
EFKON INDIA PVT. LTD.  
1115, 11th Floor, Rupa Solitaire, Building No. A-1,  
Sector 1, Millennium Business Park, Navi Mumbai  
Mahape, Thane - 400710  
CIN NO.: - U72900MH2001PTC132670

Tel. :+91 22 42949494  
Fax :+91 22 42949333  
Web.:http://www.efkonindia.com





**Form EXP - 4.2(b): Specific Construction  
Experience in Key Activities**

Key Activity No. (2): Design & Construction of Toll Management System for at least two projects, each having at least 8 Nos. toll gates (4 toll gates on each side; for two projects 16 Nos); Comprising of.

**EFKON India Private Limited**

**Project 6: GVK Deolikota**

**True Copy of the Completion Certificate**



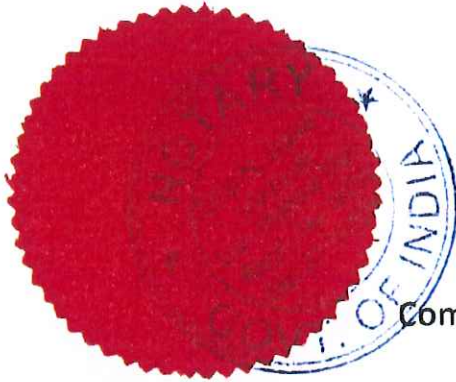

## Completion Certificate

Date: 09<sup>th</sup> July 2018

This is to certify that M/s. Efkon India Private Limited, its address being 1405 - 1408 Supremus 'E' – Wing, I Think Techno Campus, Kanjurmarg East, Mumbai 400 042, has been awarded for the Supply, Installation, System Integration, Testing, Commissioning of Toll Collection and Management System at GVK Deoli Kota Expressway Pvt. Ltd.

Implementation of the same has been successfully implemented and is running to full operational capacity.

Project Title	Design, Supply, Installation, Commissioning & Maintenance of Toll Management System
Purchase Order/Work Order ID	Contract Agreement GVK/Deoli Kota Expressway/TMS/CA No 001 dated 28.06.2013
Place of Project	Deoli Kota Section of NH 12 from KM 165 to Junction of NH 76
Type of Project	SITC with O&M
Total number of TMS Lanes	12 lanes
Number of Cash Lanes	12 lanes
Number of Hybrid ETC Lanes	12 lanes
Number of Dedicated ETC Lanes	0 lanes
Number of WIMs	12 Nos
Number of AVCC	12 Nos
Employer	GVK Deoli Kota Expressway Pvt. Ltd.
Implementation date	2015
Completion date	June 2015
System O&M period yr. 1	2015-2016
System O&M period yr. 2	2016-2017
System O&M period yr. 3	2017-2018







Scope of work:

- 1. Supply, Installation, Testing, commissioning and Maintenance of Electronic Toll Management System and SSWIM system comprising of:

- A. Lane Controller
- B. Incident Capture Camera
- C. Traffic Lights
- D. Operator Monitor and Customized Keyboard
- E. User Fare Display
- F. Automatic barrier.
- G. OHLS
- H. Barcode Scanner
- I. Receipt Printer
- J. Manual Booth Controller
- K. Smart Card Reader
- L. Siren, Panic button
- M. Booth Monitoring Camera
- N. AVCC Profiler, loop.
- O. SSWIM, vehicle separator, controller.
- P. ETC RFID and etc....

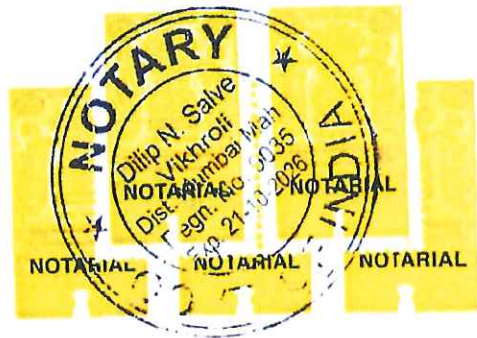

TRUE COPY

*Dilip N. Salve*  
 Dilip N. Salve  
 ADVOCATE & NOTARY  
 208 9320, Manar, CHS, Kankarnagar  
 No. 2, Vardhaji, Mumbai - 400 083

*P. V. Rao*

*Manish Jain*  
 Asst Mgr - IT

Signature & Contact details:

Name: P V Rao

Project Name: Deoli - Kota Project

Company: GVK Deoli Kota Expressway Pvt. Ltd.

Date: 09<sup>th</sup> July 2018







Form EXP - 4.2(b): Specific Construction  
Experience in Key Activities

**Key Activity No. (3):** Design, Supply, Installation, Testing & Commissioning of 11kV HV Power network complete with one number Switching Station having minimum 17 Nos. of Distribution Substations (11kV/415V) connected in 2 Nos. ring with SCADA control and monitoring system from remote location through Fiber Optic System.

**STRABAG Infrastructure & Safety Solutions GmbH**

Project 1: Klaus



STRABAG Infrastructure &amp; Safety Solutions GmbH

**STRABAG**

Form EXP - 4.2(b)

**Specific Construction Experience in Key Activities**Date: 08<sup>th</sup> December 2021

Applicant's Legal Name: JV of STRABAG Infrastructure &amp; Safety Solutions GmbH and STRABAG AG

Applicant's Party Legal Name: STRABAG Infrastructure &amp; Safety Solutions GmbH

IFB No.: MMRDA/ENG1/0002561

Page 01 of 02 pages

**Key Activity No. (3)** Design, Supply, Installation, Testing & Commissioning of 11kV HV Power network complete with one number Switching Station having minimum 17 Nos. of Distribution Substations (11kV/415V) connected in 2 Nos. ring with SCADA control and monitoring system from remote location through Fiber Optic System.

Item	Information		
Contract Identification	Pyhrn Motorway A9 – Klaus Electrical and Mechanical Works		
Award Date	May 2016		
Completion Date	December 2018		
Role in Contract	Prime Contractor		Management Contractor <input type="checkbox"/>
	Single entity <input checked="" type="checkbox"/>	JV member <input type="checkbox"/>	
Total Contract Amount	EUR 31.80 million		1 EURO = 1.1194 USD dated 10 <sup>th</sup> May 2016 and total contract amount in USD equivalent is 35.60 million
Description of the Works undertaken for demonstration	Planning, Design/Engineering, Supply, Installation, Testing & Commissioning of 24kV HV Power Supply and distribution network Switching Stations with 23 Nos. of 24kV Distribution Substations (having		





STRABAG Infrastructure & Safety Solutions GmbH  
Ignaz-Koeck-Str 19  
1210 Wien/Osterreich  
www.strabag-iss.com

Tel +43 1 90199-0  
Fax +43 1 90199-19  
siss-office@strabag.com

Raiffeisenlandesbank Oberösterreich AG  
IBAN: AT91 3400 0000 0014 1317  
BIC/SWIFT: RZOOAT2LXXX

Sitz Wien, Handelsgericht Wien, FN 79688p, UID Nr ATU14764502

Gedruckt auf 100 % Recyclingpapier



STRABAG Infrastructure &amp; Safety Solutions GmbH

**STRABAG**

of the similarity of the key activity	GIS Switchgear) connected in ring formation on 24kV main cable network with centralized SCADA control and monitoring system from remote location through Fiber Optic System.
Employer's Name:	ASFINAG BAU MANAGEMENT GMBH
Address:	ASFINAG BAU MANAGEMENT GMBH, A-5600 Bruck / Mur, Brandstetterstrasse, 54. Austria
Telephone/Fax Number:	Tel: 43 (0) 50 108- 14468 Fax: 43 (0) 50 108 - 14462
E-mail:	markus.gutjarh@asfinag.at

- Attached is a true copy of the completion certificate or other similar document(s) for the contract / project issued by the client.

For STRABAG Infrastructure &amp; Safety Solutions GmbH,

Printed Name:  
Designation:

Simranjit Singh Ratra  
Lawful Attorney



Sandeep Murarka  
Lawful Attorney



STRABAG Infrastructure & Safety Solutions GmbH  
Ignaz-Koeck-Str 19  
1210 Wien/Österreich  
www.strabag-iss.com

Tel. +43 1 90199-0  
Fax +43 1 90199-19  
siss-office@strabag.com

Raiffeisenlandesbank Oberösterreich AG  
IBAN AT91 3400 0000 0014 1317  
BIC/SWIFT RZOOAT2LXXX

Sitz Wien, Handelsgericht Wien, FN 79688p, UID Nr ATU14764502

Gedruckt auf 100 % Recyclingpapier



Form EXP - 4.2(b): Specific Construction  
Experience in Key Activities

**Key Activity No. (3):** Design, Supply, Installation, Testing & Commissioning of 11kV HV Power network complete with one number Switching Station having minimum 17 Nos. of Distribution Substations (11kV/415V) connected in 2 Nos. ring with SCADA control and monitoring system from remote location through Fiber Optic System.

**STRABAG Infrastructure & Safety Solutions GmbH**

Project 1: Klaus

True Copy of the Completion Certificate





Date:

Letter of reference

Dear Sir or Madam, (To whom it may concern)

As the client we herewith confirm that the company STRABAG Infrastructure & Safety Solutions GmbH, Breitwies 32, A 5303 Thalgau, Austria performed the construction works for the project described below in accordance with the contractual provisions, with a high quality of engineering and to our fullest satisfaction

Project name:	Pyhrn Motorway A9 – Completion Klaus Tunnel Chain Electrical and Mechanical Equipment
Place of project	Klaus/Austria
Contract value	EUR 31.83 Mio net
Total billing amount	EUR 35.58 Mio net
Start Date of Project	05/2016
Date of Project Completion:	12/2018
Scheduled date of Completion:	12/2018

**Project Description**

The project includes the entire electromechanical and electrical reconstruction of the Klaus tunnel chain.

This mainly includes equipping:

- 4 new tubes (Falkenstein, Spering, Traunfried, and Klaus) in the direction of Linz
- 4 existing tubes (Falkenstein, Spering, Traunfried, and Klaus) in the direction of Graz
- 6 operations buildings, 7 electrical niches and one cavern

The project further includes the construction of the CN.as line (without ground excavation work) between the Kienberg tunnel and the Rossleithen interchange including connection and extension of the existing open-air installations. Renovation of the medium-voltage switchgear (control system/protective equipment) between the Tretter tunnel and the Rossleithen tunnel was also implemented during the project

4 tunnels each with 2 tubes/travel directions (total approx. 12.55 km)

- Klaus tunnel 2,166 m
- Traunfried tunnel: 462 m
- Spering tunnel: 2,894 m
- Falkenstein tunnel 752 m



BMG/EM/PL/Gutjahr  
13. Dez. 2021  
ASFINAG BAU MANAGEMENT GMBH  
im Vollmachtsnamen der ASFINAG



# ASFINAG

GUTE FAHRT ÖSTERREICH

The Project involves Planning, Engineering, Supply Erection, Implementing, Testing & Commissioning of

Systems	Value of Component
<ul style="list-style-type: none"> <li>24kV HV Power Supply and distribution network Switching Stations with 24 Nos. of 24kV Distribution Substations (having GIS Switchgear) connected in ring formation on 24kV main cable network</li> <li>24kV HT cable along with associated activities</li> <li>LT &amp; HT panel</li> <li>Transformers</li> <li>DG set of 500 kVA (connection point)</li> <li>Substation civil work</li> <li>Electrical steel structures</li> <li>Cable tray</li> <li>UPS</li> <li>Tunnel lighting</li> <li>Road lighting</li> <li>Actuated Traffic Controller</li> <li>Traffic control system including traffic sign posts</li> <li>Video surveillance including acoustic tunnel monitoring</li> <li>Emergency call equipment</li> <li>Public address system</li> <li>Variable message sign boards</li> <li>Radio system</li> <li>Hazard warning system</li> <li>Entire control system including data transmission equipment</li> <li>Construction / Installation of buildings and niches</li> </ul>	EUR 31.45 Mio
<ul style="list-style-type: none"> <li>Tunnel ventilation system and its associated DB's with Soft starter panel, LT Cables &amp; Sensors</li> <li>Environmental data acquisition system in the open air</li> <li>Building ventilation and air conditioning system</li> <li>SCADA System Consisting of Master control / Station Involving RTUs / PLC with each RTUs / PLC being PC / Microprocessor based, remotely located and connected through fiber optic cable and controlled in un-manned condition</li> <li>Firefighting system and prevention system including pumps, piping and all associated systems</li> </ul>	EUR 2.00 Mio EUR 1.56 Mio EUR 0.57 Mio
<b>TOTAL</b>	<b>EUR 35.58 Mio</b>

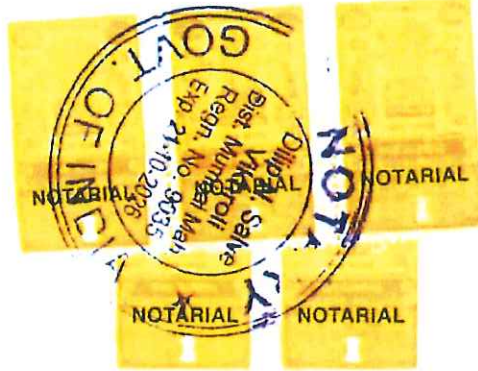

The contracted works were performed punctually, to our full satisfaction, in accordance with the state of the art, and in compliance with the safety standards, the relevant prescriptions and contractual provisions

ASFINAG as the Client is satisfied with the performance of this project and the result of the works and confirms the satisfactory and constructive collaboration with STRABAG Infrastructure & Safety Solutions GmbH

Best Regards

ASFINAG BAU MANAGEMENT GMBH

TRUE COPY

*A. Salve*

*13 Dec 2021*

Dilip N. Salve  
Advocate & Notary Public

NOTARY  
Dilip N. Salve  
Vikhroli  
Dist. Mumbai Mah  
Regn. No. 9035  
Exp. 21.10.2026

GOVT. OF INDIA

*[Signature]*

BMG/EM/PL/Gutjahr  
13. Dez. 2021

ASFINAG BAU MANAGEMENT GMBH  
im Vollmachtenamen der ASFINAG



ASFINAG Bau Management GmbH





Page Intentionally left blank



Page Intentionally left blank





Form EXP - 4.2(b): Specific Construction  
Experience in Key Activities

**Key Activity No. (3):** Design, Supply, Installation, Testing & Commissioning of 11kV HV Power network complete with one number Switching Station having minimum 17 Nos. of Distribution Substations (11kV/415V) connected in 2 Nos. ring with SCADA control and monitoring system from remote location through Fiber Optic System.

**STRABAG Infrastructure & Safety Solutions GmbH**

Project 2: Langen



1659 A

STRABAG Infrastructure &amp; Safety Solutions GmbH



Form EXP - 4.2(b)

## Specific Construction Experience in Key Activities

Date: 13<sup>th</sup> December 2021

Applicant's Legal Name: JV of STRABAG Infrastructure &amp; Safety Solutions GmbH and STRABAG AG

Applicant's Party Legal Name: STRABAG Infrastructure &amp; Safety Solutions GmbH

IFB No.: MMRDA/ENG1/0002561

Page 01 of 02 pages

**Key Activity No. (3)** Design, Supply, Installation, Testing & Commissioning of 11kV HV Power network complete with one number Switching Station having minimum 17 Nos. of Distribution Substations (11kV/415V) connected in 2 Nos. ring with SCADA control and monitoring system from remote location through Fiber Optic System.

Item	Information		
Contract Identification	Arlberg Expressway S16 – Langen Electrical and Mechanical Equipment		
Award Date	December 2017		
Completion Date	October 2019		
Role in Contract	Prime Contractor		Management Contractor <input type="checkbox"/>
	Single entity <input checked="" type="checkbox"/>	JV member <input type="checkbox"/>	
Total Contract Amount	EUR 11.14 million		1 EURO = 1.1820 USD dated 05 <sup>th</sup> December 2017 and total contract amount in USD equivalent is 13.17 million
Description of the Works undertaken for demonstration	Planning, Design/Engineering, Supply, Installation, Testing & Commissioning of 36kV HV Power Supply and distribution network Switching Stations with 18 Nos. of 36kV Distribution Substations (having		



STRABAG Infrastructure & Safety Solutions GmbH  
Ignaz-Koeck-Str 19  
1210 Wien/Österreich  
www.strabag-iss.com

Tel +43 1 90199-0  
Fax +43 1 90199-19  
siss-office@strabag.com

Raiffeisenlandesbank Oberösterreich AG  
IBAN AT91 3400 0000 0014 1317  
BIC/SWIFT RZOOAT2LXXX

Sitz: Wien, Handelsgencht Wien, FN 79688p, UID Nr. ATU14764502

Gedruckt auf 100 % Recyclingpapier



1659 B



STRABAG Infrastructure &amp; Safety Solutions GmbH

**STRABAG**

of the similarity of the key activity	<b>GIS Switchgear) connected in ring formation on 36kV main cable network with centralized SCADA control and monitoring system from remote location through Fiber Optic System.</b>
Employer's Name:	ASFINAG BAU MANAGEMENT GMBH
Address:	ASFINAG BAU MANAGEMENT GMBH, A-9523, Villach, Steinbruchstrasse 2a. Austria
Telephone/Fax Number:	Tel: 43 (0) 50 108- 14560 Fax: 43 (0) 50 108 - 14552
E-mail:	wolfgang.wissouig@asinag.at

- Attached is a true copy of the completion certificate or other similar document(s) for the contract / project issued by the client.

For STRABAG Infrastructure &amp; Safety Solutions GmbH,

Printed Name:  
Designation:

Simranjit Singh Ratra  
Lawful Attorney



Sandeep Murarka  
Lawful Attorney



STRABAG Infrastructure & Safety Solutions GmbH  
Ignaz-Koeck-Str 19  
1210 Wien/Osterreich  
www.strabag-iss.com

Tel. +43 1 90199-0  
Fax +43 1 90199-19  
siss-office@strabag.com

Raiffeisenlandesbank Oberosterr. AG  
IBAN: AT91 3400 0000 0014 1317  
BIC/SWIFT: RZ0OAT2LXXX

Sitz: Wien, Handelsgericht Wien, FN 79688p, UID Nr. ATU14764502

Gedruckt auf 100 % Recyclingpapier



1659 C

Form EXP - 4.2(b): Specific Construction  
Experience in Key Activities

**Key Activity No. (3):** Design, Supply, Installation, Testing & Commissioning of 11kV HV Power network complete with one number Switching Station having minimum 17 Nos. of Distribution Substations (11kV/415V) connected in 2 Nos. ring with SCADA control and monitoring system from remote location through Fiber Optic System.

**STRABAG Infrastructure & Safety Solutions GmbH**

Project 2: Langen

True Copy of the Completion Certificate



1659 D







Systems	Value Tunnel Langen
<ul style="list-style-type: none"> <li>• Video surveillance including acoustic tunnel monitoring</li> <li>• Emergency call equipment</li> <li>• Public address system</li> <li>• Variable message sign boards</li> <li>• Radio system</li> <li>• Hazard warning system</li> <li>• Entire control system including data transmission equipment</li> <li>• Construction / Installation of buildings and niches</li> </ul>	
<ul style="list-style-type: none"> <li>• Tunnel ventilation system and its associated DB's with Soft starter panel, LT Cables &amp; Sensors</li> <li>• Environmental data acquisition system in the open air</li> <li>• Building ventilation and air conditioning system</li> </ul>	EUR 0.78 Mio
<ul style="list-style-type: none"> <li>• SCADA System Consisting of Master control / Station involving PLC with each PLC being PC / Microprocessor based, remotely located and connected through fiber optic cable and controlled in un-manned condition.</li> </ul>	EUR 0.44 Mio
<ul style="list-style-type: none"> <li>• Firefighting and prevention system including pumps, piping and all associated systems.</li> </ul>	EUR 0.18 Mio
<b>Total Contract value without Taxes</b>	<b>EUR 9.29 Mio</b>
Taxes @ 20%	EUR 1.85 Mio
<b>Total Contract value with Taxes</b>	<b>EUR 11.14 Mio</b>

The contracted works were performed punctually, to our full satisfaction, in accordance with the state of the art, and in compliance with the safety standards, the relevant prescriptions and contractual provisions.

ASFINAG as the Client is satisfied with the performance of this project and the result of the works, and confirms the satisfactory and constructive collaboration with STRABAG Infrastructure & Safety Solutions GmbH.

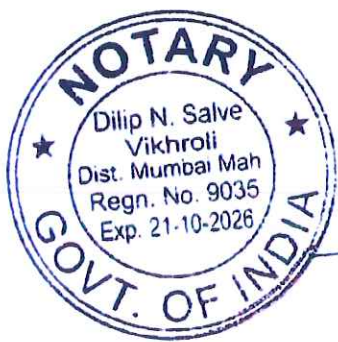

**TRUE COPY**  
*Dilip N. Salve*  
13/12/24  
**Dilip N. Salve**  
ADVOCATE & NOTARY  
238 9320, Manas CHS, Khandamwar Nagar  
No. 2, Vikhroli, Dist. Mumbai, Pin-400 083

Best regards



Wolfgang Wissounig

Mario Patigler

ASFINAG BAU MANAGEMENT GMBH  
im Vollmachtsnamen der ASFINAG



**ASFINAG Bau Management GmbH**

Madrigalerstr. 11  
1140 Wien  
E-Mail: bau@asfinag.at  
www.asfinag.at

UID: ATU8142533, BAN AT1600000090030731, BIC BAWA3300  
Firmenbuchnummer Handelsregister Wien: FN 255611d  
Rechtsform: Gesellschaft mit beschränkter Haftung  
TUV Süd Zertifikat: 21010214, 21010215, 21010216





Form EXP - 4.2(b): Specific Construction  
Experience in Key Activities

**Key Activity No. (4):** Design, Supply, Installation, Testing & Commissioning of Illumination of Road/Bridge Lighting with control & monitoring system for at least 22km length.

**STRABAG Infrastructure & Safety Solutions GmbH**

Project 1: Klaus
Project 2 : Langen
Project 3 : Oswaldiberg



Form EXP - 4.2(b): Specific Construction  
Experience in Key Activities

Key Activity No. (4): Design, Supply, Installation,  
Testing & Commissioning of Illumination of Road/  
Bridge Lighting with control & monitoring system  
for at least 22km length.

**STRABAG Infrastructure & Safety Solutions GmbH**

Project 1: Klaus





STRABAG Infrastructure &amp; Safety Solutions GmbH

**STRABAG**

## Form EXP - 4.2(b)

## Specific Construction Experience in Key Activities

Date: 08<sup>th</sup> December 2021

Applicant's Legal Name: JV of STRABAG Infrastructure &amp; Safety Solutions GmbH and STRABAG AG

Applicant's Party Legal Name: STRABAG Infrastructure &amp; Safety Solutions GmbH

IFB No.: MMRDA/ENG1/0002561

Page 01 of 02 pages

**Key Activity No. (4)** Design, Supply, Installation, Testing & Commissioning of Illumination of Road/ Bridge Lighting with control & monitoring system for at least 22km length.

Item	Information		
Contract Identification	Pyhrn Motorway A9 – Klaus Electrical and Mechanical Works		
Award Date	May 2016		
Completion Date	December 2018		
Role in Contract	Prime Contractor		Management Contractor <input type="checkbox"/>
	Single entity <input checked="" type="checkbox"/>	JV member <input type="checkbox"/>	
Total Contract Amount	EUR 31.80 million		1 EURO = 1.1194 USD dated 10 <sup>th</sup> May 2016 and total contract amount in USD equivalent is 35.60 million
Description of the Works undertaken for demonstration of the similarity of the key activity	Planning, Design/Engineering, Supply, Installation, Testing & Commissioning of Illumination of Road Lighting covering complete stretch of 12.55 Kms with approx. 2,200 nos. road lights with control & monitoring system including SCADA System		



STRABAG Infrastructure & Safety Solutions GmbH  
 Ignaz-Koeck-Str. 19  
 1210 Wien/Österreich  
 www.strabag-iss.com

Tel. +43 1 90199-0  
 Fax +43 1 90199-19  
 siss-office@strabag.com

Raiffeisenlandesbank Oberösterreich AG  
 IBAN: AT91 3400 0000 0014 1317  
 BIC/SWIFT: RZOOAT2LXXX

Sitz Wien, Handelsgericht Wien FN 79688p UID Nr. ATU14764502

Gedruckt auf 100 % Recyclingpapier



STRABAG Infrastructure &amp; Safety Solutions GmbH

**STRABAG**

Employer's Name:	ASFINAG BAU MANAGEMENT GMBH
Address:	ASFINAG BAU MANAGEMENT GMBH, A-5600 Bruck / Mur, Brandstetterstrasse, 54. Austria
Telephone/Fax Number:	Tel: 43 (0) 50 108- 14468 Fax: 43 (0) 50 108 - 14462
E-mail:	markus.gutjarh@asfinag.at

- Attached is a true copy of the completion certificate or other similar document(s) for the contract / project issued by the client.

For STRABAG Infrastructure &amp; Safety Solutions GmbH,

Printed Name:  
Designation:

Simranjit Singh Ratra  
Lawful Attorney



Sandeep Murarka  
Lawful Attorney



STRABAG Infrastructure & Safety Solutions GmbH  
Ignaz-Koeck-Sir 19  
1210 Wien/Osterreich  
www.strabag-iss.com

Tel +43 1 90199-0  
Fax +43 1 90199-19  
siss-office@strabag.com

Raiffeisenlandesbank Oberosterr. AG  
IBAN AT91 3400 0000 0014 1317  
BIC/SWIFT RZOOAT2LXXX

Sitz Wien, Handelsgericht Wien, FN 79688p, UID Nr ATU14764502

Gedruckt auf 100 % Recyclingpapier





Form EXP - 4.2(b): Specific Construction  
Experience in Key Activities

Key Activity No. (4): Design, Supply, Installation,  
Testing & Commissioning of Illumination of Road/  
Bridge Lighting with control & monitoring system  
for at least 22km length.

**STRABAG Infrastructure & Safety Solutions GmbH**

Project 1: Klaus

True Copy of the Completion Certificate



Date:  
 Letter of reference

Dear Sir or Madam, (To whom it may concern)

As the client we herewith confirm that the company STRABAG Infrastructure & Safety Solutions GmbH, Breitwies 32, A 5303 Thalgau, Austria performed the construction works for the project described below in accordance with the contractual provisions, with a high quality of engineering and to our fullest satisfaction

Project name:	Pyhrn Motorway A9 – Completion Klaus Tunnel Chain Electrical and Mechanical Equipment
Place of project	Klaus/Austria
Contract value	EUR 31.83 Mio net
Total billing amount	EUR 35.58 Mio net
Start Date of Project	05/2016
Date of Project Completion	12/2018
Scheduled date of Completion	12/2018



#### Project Description

The project includes the entire electromechanical and electrical reconstruction of the Klaus tunnel chain.

This mainly includes equipping

- 4 new tubes (Falkenstein, Spering, Traunfried, and Klaus) in the direction of Linz
- 4 existing tubes (Falkenstein, Spering, Traunfried, and Klaus) in the direction of Graz
- 6 operations buildings, 7 electrical niches and one cavern

The project further includes the construction of the CN as line (without ground excavation work) between the Kienberg tunnel and the Rossleithen interchange including connection and extension of the existing open-air installations. Renovation of the medium-voltage switchgear (control system/protective equipment) between the Tretter tunnel and the Rossleithen tunnel was also implemented during the project

4 tunnels each with 2 tubes/travel directions (total approx. 12.55 km)

- Klaus tunnel: 2,166 m
- Traunfried tunnel: 462 m
- Spering tunnel: 2,894 m
- Falkenstein tunnel: 752 m



BMG/EM/PL/Outjahr  
 13. Dez. 2021  
 ASFINAG BAU MANAGEMENT GMBH  
 im Vollmachtsnamen der ASFINAG





The Project involves Planning, Engineering, Supply Erection, Implementing, Testing & Commissioning of

Systems	Value of Component
<ul style="list-style-type: none"> <li>24kV HV Power Supply and distribution network Switching Stations with 24 Nos. of 24kV Distribution Substations (having GIS Switchgear) connected in ring formation on 24kV main cable network</li> <li>24kV HT cable along with associated activities</li> <li>LT &amp; HT panel</li> <li>Transformers</li> <li>DG set of 500 kVA (connection point)</li> <li>Substation civil work</li> <li>Electrical steel structures</li> <li>Cable tray</li> <li>UPS</li> <li>Tunnel lighting</li> <li>Road lighting</li> <li>Actuated Traffic Controller</li> <li>Traffic control system including traffic sign posts</li> <li>Video surveillance including acoustic tunnel monitoring</li> <li>Emergency call equipment</li> <li>Public address system</li> <li>Variable message sign boards</li> <li>Radio system</li> <li>Hazard warning system</li> <li>Entire control system including data transmission equipment</li> <li>Construction / Installation of buildings and niches</li> </ul>	EUR 31.45 Mio
<ul style="list-style-type: none"> <li>Tunnel ventilation system and its associated DB's with Soft starter panel, LT Cables &amp; Sensors</li> <li>Environmental data acquisition system in the open air</li> <li>Building ventilation and air conditioning system</li> <li>SCADA System Consisting of Master control / Station Involving RTUs / PLC with each RTUs / PLC being PC / Microprocessor based, remotely located and connected through fiber optic cable and controlled in un-manned condition</li> <li>Firefighting system and prevention system including pumps, piping and all associated systems.</li> </ul>	EUR 2.00 Mio EUR 1.56 Mio EUR 0.57 Mio
<b>TOTAL</b>	<b>EUR 35.58 Mio</b>

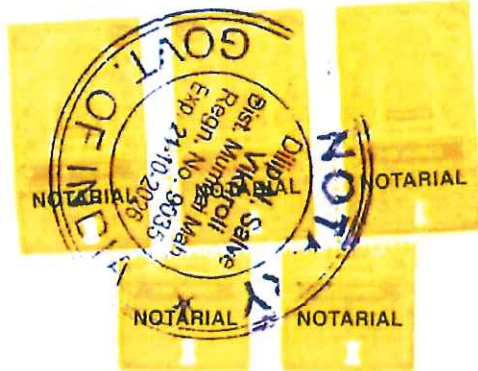

The contracted works were performed punctually, to our full satisfaction, in accordance with the state of the art, and in compliance with the safety standards, the relevant prescriptions and contractual provisions

ASFINAG as the Client is satisfied with the performance of this project and the result of the works and confirms the satisfactory and constructive collaboration with STRABAG Infrastructure & Safety Solutions GmbH

Best Regards

ASFINAG BAU MANAGEMENT GMBH

**TRUE COPY**  
Dilip N. Salve  
13  
Adv. & Notary  
133

**BMG/EM/PL/Gutjahr**  
13. Dez. 2021  
ASFINAG BAU MANAGEMENT GMBH  
im Vollmachtenamen der ASFINAG



ASFINAG Bau-Management GmbH



Form EXP - 4.2(b): Specific Construction  
Experience in Key Activities

Key Activity No. (4): Design, Supply, Installation,  
Testing & Commissioning of Illumination of Road/  
Bridge Lighting with control & monitoring system  
for at least 22km length.

**STRABAG Infrastructure & Safety Solutions GmbH**

Project 2 : Langen





STRABAG Infrastructure &amp; Safety Solutions GmbH

**STRABAG**

Form EXP - 4.2(b)

**Specific Construction Experience in Key Activities**Date: 13<sup>th</sup> December 2021

Applicant's Legal Name: JV of STRABAG Infrastructure &amp; Safety Solutions GmbH and STRABAG AG

Applicant's Party Legal Name: STRABAG Infrastructure &amp; Safety Solutions GmbH

IFB No.: MMRDA/ENG1/0002561

Page 01 of 02 pages

**Key Activity No. (4)** Design, Supply, Installation, Testing & Commissioning of Illumination of Road/ Bridge Lighting with control & monitoring system for at least 22km length.

Item	Information		
Contract Identification	Arlberg Expressway S16 – Langen Electrical and Mechanical Equipment		
Award Date	December 2017		
Completion Date	October 2019		
Role in Contract	Prime Contractor		Management Contractor <input type="checkbox"/>
	Single entity <input checked="" type="checkbox"/>	JV member <input type="checkbox"/>	
Total Contract Amount	EUR 11.14 million	1 EURO = 1.1820 USD dated 05 <sup>th</sup> December 2017 and total contract amount in USD equivalent is 13.17 million	
Description of the Works undertaken for demonstration of the similarity of the key activity	Planning, Design/Engineering, Supply, Installation, Testing & Commissioning of Illumination of Road Lighting covering complete stretch of 4.6 Kms with approx. 700 nos. road lights with control & monitoring system including SCADA System		



STRABAG Infrastructure & Safety Solutions GmbH  
 Ignaz-Koeck-Str. 19  
 12110 Wien/Osterreich  
 www.strabag-iss.com

Tel +43 1 90199-0  
 Fax +43 1 90199-19  
 siss-office@strabag.com

Raiffeisenlandesbank Oberösterreich AG  
 IBAN: AT91 3400 0000 0014 1317  
 BIC/SWIFT: RZOOAT2LXXX

Sitz: Wien, Handelsgericht Wien, FN 79688p, UID Nr. ATU14764502

Gedruckt auf 100 % Recyclingpapier



1668

STRABAG Infrastructure &amp; Safety Solutions GmbH

**STRABAG**

Employer's Name:	ASFINAG BAU MANAGEMENT GMBH
Address:	ASFINAG BAU MANAGEMENT GMBH, A—9523, Villach, Steinbruchstrasse 2a. Austria
Telephone/Fax Number:	Tel: 43 (0) 50 108- 14560 Fax: 43 (0) 50 108 - 14552
E-mail:	wolfgang.wissouig@asinag.at

- Attached is a true copy of the completion certificate or other similar document(s) for the contract / project issued by the client.

For STRABAG Infrastructure &amp; Safety Solutions GmbH,

Printed Name:  
Designation:

Simranjit Singh Ratra  
Lawful Attorney



Sandeep Murarka  
Lawful Attorney



STRABAG Infrastructure & Safety Solutions GmbH  
Ignaz-Koeck-Str 19  
1210 Wien/Osterreich  
www.strabag-iss.com

Tel +43 1 90199-0  
Fax +43 1 90199-19  
siss-office@strabag.com

Raiffeisenlandesbank Oberösterreich AG  
IBAN: AT91 3400 0000 0014 1317  
BIC/SWIFT: RZ00AT2LXXX

Sitz: Wien, Handelsgericht Wien, FN 79688p, UID Nr. ATU14764502

Gedruckt auf 100 % Recyclingpapier





Form EXP - 4.2(b): Specific Construction  
Experience in Key Activities

Key Activity No. (4): Design, Supply, Installation,  
Testing & Commissioning of Illumination of Road/  
Bridge Lighting with control & monitoring system  
for at least 22km length.

**STRABAG Infrastructure & Safety Solutions GmbH**

Project 2 : Langen

True Copy of the Completion Certificate









Form EXP - 4.2(b): Specific Construction  
Experience in Key Activities

Key Activity No. (4): Design, Supply, Installation,  
Testing & Commissioning of Illumination of Road/  
Bridge Lighting with control & monitoring system  
for at least 22km length.

**STRABAG Infrastructure & Safety Solutions GmbH**

Project 3 : Oswaldiberg





STRABAG Infrastructure &amp; Safety Solutions GmbH

**STRABAG**

## Form EXP - 4.2(b)

## Specific Construction Experience in Key Activities

Date: 08<sup>th</sup> December 2021

Applicant's Legal Name: JV of STRABAG Infrastructure &amp; Safety Solutions GmbH and STRABAG AG

Applicant's Party Legal Name: STRABAG Infrastructure &amp; Safety Solutions GmbH

IFB No.: MMRDA/ENG1/0002561

Page 01 of 02 pages

**Key Activity No. (4)** Design, Supply, Installation, Testing & Commissioning of Illumination of Road/ Bridge Lighting with control & monitoring system for at least 22km length.

Item	Information		
Contract Identification	Motorway A10 –Oswaldiberg Electrical and Mechanical Equipment		
Award Date	July 2015		
Completion Date	June 2017		
Role in Contract	Prime Contractor		Management Contractor <input type="checkbox"/>
	Single entity <input checked="" type="checkbox"/>	JV member <input type="checkbox"/>	
Total Contract Amount	EUR 32.99 million		1 EURO = 1.1085 USD dated 01 <sup>st</sup> July 2015 and total contract amount in USD equivalent is 36.57 million
Description of the Works undertaken for demonstration of the similarity of the key activity	Planning, Design/Engineering, Supply, Installation, Testing & Commissioning of Illumination of Road Lighting covering complete stretch of 8.6 Kms with approx. 1,200 nos. road lights with control & monitoring system including SCADA System.		



*[Handwritten signature]*



*[Handwritten signature]*

STRABAG Infrastructure & Safety Solutions GmbH  
Ignaz-Koeck-Str 19  
1210 Wien/Österreich  
www.strabag-iss.com

Tel +43 1 90199-0  
Fax +43 1 90199-19  
sis-office@strabag.com

Raiffeisenlandesbank Oberösterreich AG  
IBAN: AT91 3400 0000 0014 1317  
BIC/SWIFT: RZOOAT2LXXX

Sitz: Wien, Handelsgericht Wien, FN 79688p, UID Nr. ATU14764502

Gedruckt auf 100 % Recyclingpapier



1674

STRABAG Infrastructure &amp; Safety Solutions GmbH

**STRABAG**

Employer's Name:	ASFINAG BAU MANAGEMENT GMBH
Address:	ASFINAG BAU MANAGEMENT GMBH, Modecenterstrasse 16, 1030 Vienna, Austria
Telephone/Fax Number:	Tel: 43 (0) 50 108- 14560 Fax: 43 (0) 50 108 - 14552
E-mail:	wolfgang.wissouig@asinag.at

- Attached is a true copy of the completion certificate or other similar document(s) for the contract / project issued by the client.

For STRABAG Infrastructure &amp; Safety Solutions GmbH,

Printed Name:  
Designation:

Simranjit Singh Ratra  
Lawful Attorney



Sandeep Murarka  
Lawful Attorney



STRABAG Infrastructure & Safety Solutions GmbH  
Ignaz-Koeck-Str 19  
1210 Wien/Osterreich  
www.strabag-iss.com

Tel +43 1 90199-0  
Fax +43 1 90199-19  
siss-office@strabag.com

Raiffeisenlandesbank Obersterr AG  
IBAN: AT91 3400 0000 0014 1317  
BIC/SWIFT RZGOAT2LXXX

Sitz Wien, Handelsgericht Wien, FN 79688p, UID Nr ATU14764502

Gedruckt auf 100 % Recyclingpapier





Form EXP - 4.2(b): Specific Construction  
Experience in Key Activities

Key Activity No. (4): Design, Supply, Installation,  
Testing & Commissioning of Illumination of Road/  
Bridge Lighting with control & monitoring system  
for at least 22km length.

**STRABAG Infrastructure & Safety Solutions GmbH**

Project 3 : Oswaldiberg

True Copy of the Completion Certificate





Letter of reference

Dear Sir or Madam, (To whom it may concern)

As the client we herewith confirm that the company STRABAG Infrastructure & Safety Solutions GmbH, Breitwies 32, A-5303 Thalgau, Austria performed the construction works for the project described below in accordance with the contractual provisions, with a high quality of engineering and to our fullest satisfaction.

Project name: Motorway A10 - Oswaldiberg Tunnel refurbishment

Contract value: EUR 32.99 Mio. net  
 Total billing amount: EUR 36.89 Mio. net

Start Date of Project: 07/2015  
 Date of Project Completion: 06/2017  
 Scheduled date of Completion: 06/2017

Project Description

- Total tunnel length, traffic direction of Villach: 4,297 m
- Total tunnel length, traffic direction of Salzburg: 4,307 m

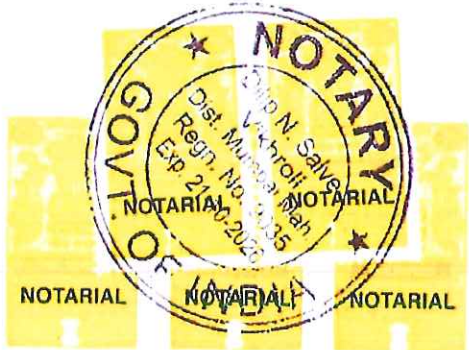

ASFINAG SA / MANAGEMENT GMBH  
 Rechtsform: Gesellschaft n.d.H. (GmbH) Wien - H 2526313, Handelsgericht Handelsregister Wien  
 UID-Nummer: ATU 61242533, Gerichtsbezirk: Salzburg 3001, 3008, CIV. AC, JURIA, Gerichtsbezirk: Salzburg 3001, 3008, 3009

4-1040 WIEN, MOEDLSTADTSTRASSE 16/1  
 TEL: +43 (0) 50 108 11000 FAX: +43 (0) 50 108 10020  
 E-Mail: baumanagement@asfinag.at, info@asfinag.at





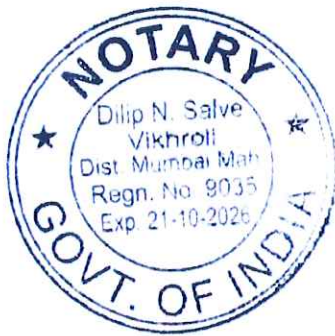

The Project involves Supply, Erection, Testing & Commissioning of:

Systems	Value of Component
<ul style="list-style-type: none"> <li>• LT &amp; HT panel</li> <li>• DG set of 500 KVA</li> <li>• Substation civil work</li> <li>• Electrical steel structures</li> <li>• Cable tray</li> <li>• UPS</li> <li>• Tunnel lighting</li> <li>• Road lighting</li> <li>• Traffic Controller</li> <li>• Traffic control system including traffic sign posts</li> <li>• Video surveillance including acoustic tunnel monitoring</li> <li>• Emergency call equipment</li> <li>• Public address system</li> <li>• Variable message sign boards</li> <li>• Radio system</li> <li>• Hazard warning system</li> <li>• Entire control system including data transmission equipment</li> <li>• Construction / Installation of buildings and niches</li> </ul>	EUR 34.48
<ul style="list-style-type: none"> <li>• Tunnel ventilation system and its associated DB's with Soft starter panel, LT Cables &amp; Sensors</li> </ul>	EUR 0.67
<ul style="list-style-type: none"> <li>• Environmental data acquisition system in the open air</li> <li>• Building ventilation and air conditioning system</li> </ul>	EUR 0.79
<ul style="list-style-type: none"> <li>• SCADA System Consisting of Master control / Station Involving RTUs / PLC with each RTUs / PLC being PC / Microprocessor based, remotely located and controlled in un-manned condition.</li> </ul>	EUR 0.95
<ul style="list-style-type: none"> <li>• Firefighting system including pumps, piping and all associated systems.</li> </ul>	EUR 0.95
<b>TOTAL</b>	<b>EUR 36.89</b>

**TRUE COPY**  
*Dilip N. Salve*  
**Dilip N. Salve**  
 ADVOCATE & NOTARY  
 238 9329, Manoj CHS, Kannamwar Nagar  
 No. 2, Vikhroli, Mumbai - 400 083

The contracted works were performed punctually, to our full satisfaction, in accordance with the state of the art and in compliance with the safety standards, the relevant prescriptions and contractual provisions.

**ASFINAG**  
**ASFINAG BAU MANAGEMENT GMBH**  
 A-9523 Villach Steinbruchstraße 2a  
 TEL +43 (0) 50 108 - 14500  
 FAX +43 (0) 50 108 - 14501  
 www.asfinag.at

*ASFINAG contract No. 30150/1908*

**11. März 2020** *[Signature]* BMG/EM/Keller  
 Best Regards  
 ASFINAG BAU MANAGEMENT GMBH



ASFINAG BAU MANAGEMENT GMBH  
 Rechtsform Gesellschaft m.b.H. Sitz Wien, FN 155611 t, Firmenbuchgericht Handelsgericht Wien  
 UID-Nummer ATU 1282531, Firmenbuch-Nr. 20012008, 09 AUGUSTINA Ferdl/Kar Str. 10100102004318

A-1030 WIEN, MODECENTERSTRASSE 16/3  
 TEL +43 (0) 50 108-14000, FAX +43 (0) 50 108-14020  
 E-MAIL: baumanagement@asfinag.at, asfinag.at

Form EXP - 4.2(b): Specific Construction  
Experience in Key Activities

**Key Activity No. (5)**

- a) Design and Construction of Administrative/Commercial Buildings having built up area of about 4000 sqm, including Complete Architectural, Structural, Mechanical, Electrical, Plumbing & Fire Fighting (ASMEP&F) works.
- b) Design and Construction of 8 Nos. of toll gates including complete Architectural, Structural, Mechanical, Electrical, Plumbing and Fire Fighting (ASMEP&F) works.





Form EXP - 4.2(b): Specific Construction  
Experience in Key Activities

**Key Activity No. (5)**

- a) Design and Construction of Administrative/Commercial Buildings having built up area of about 4000 sqm, including Complete Architectural, Structural, Mechanical, Electrical, Plumbing & Fire Fighting (ASMEP&F) works.

**STRABAG AG**

Project 1: ORBI Tower, Town Town

Project 2: Pavilions Parliamentary



Form EXP - 4.2(b): Specific Construction  
Experience in Key Activities

**Key Activity No. (5)**

- a) Design and Construction of Administrative/Commercial Buildings having built up area of about 4000 sqm, including Complete Architectural, Structural, Mechanical, Electrical, Plumbing & Fire Fighting (ASMEP&F) works.

**STRABAG AG**

Project 1: ORBI Tower, Town Town





STRABAG AG

**STRABAG**

## Form EXP - 4.2(b)

## Specific Construction Experience in Key Activities

Date: 08<sup>th</sup> December 2021

Applicant's Legal Name: JV of STRABAG Infrastructure &amp; Safety Solutions GmbH and STRABAG AG

Applicant's Party Legal Name: STRABAG AG

IFB No.: MMRDA/ENG1/0002561

Page 01 of 02 pages

## Key Activity No. (5)

a) Design and Construction of Administrative/Commercial Buildings having built up area of about 4000 sqm, including Complete Architectural, Structural, Mechanical, Electrical, Plumbing & Fire Fighting (ASMEP&F) works.

Item	Information		
Contract Identification	ORBI Tower, TownTown		
Award Date	28 <sup>th</sup> April 2015		
Completion Date	26 <sup>th</sup> June 2017		
Role in Contract	Prime Contractor		Management Contractor <input type="checkbox"/>
	Single entity <input checked="" type="checkbox"/>	JV member <input type="checkbox"/>	
Total Contract Amount	EUR 47.475 million		1 EURO = 1.0979 USD dated 28 <sup>th</sup> April 2015 and total contract amount in USD equivalent is 52.12 million
Description of the Works undertaken for demonstration of the similarity of the key activity	Detailed architectural engineering and construction work, including shop drawing, structural engineering, building services (HVACR), building control, electrical engineering, structural fire protection (ASMEP&F) works for the office building having total build up area of 20,380 sqm.		
Employer's Name:	TownTown Infra GmbH		

STRABAG AG  
Ortenburgerstr 27  
9800 Spittal an der Drau/Austria

Tel: +43 4762 620-640  
Fax: +43 4762 620-788

Erste Group Bank AG  
IBAN: AT98 2010 04031093 6900  
BIC/SWIFT: GIBAATWGXXX

Registered Office: Spittal an der Drau, Landesgericht: Klagenfurt, FN 61689w, VAT No. ATU14487107

Printed on 100 % recycled paper

STRABAG AG

**STRABAG**

Address:	Thomas-Klestil-Platz 13, 1030 Vienna, Austria
Telephone/Fax Number:	Tel: 43 (1) 531 23 - 74267
E-mail:	office@towntown.at

- Attached is a true copy of the completion certificate or other similar document(s) for the contract / project issued by the client.

For STRABAG AG,

Printed Name:  
Designation:

Rajat Kumar Mishra  
Lawful Attorney



Manoj Kumar  
Lawful Attorney



STRABAG AG  
Ortenburgerstr 27  
9800 Spittal an der Drau/Austria

Tel +43 4762 620-640  
Fax +43 4762 620-788

Erste Group Bank AG  
IBAN: AT98 2010 04031093 6900  
BIC/SWIFT: GIBAATWGXXX

Registered Office: Spittal an der Drau, Landesgericht Klagenfurt, FN 61689w, VAT No. ATU14487107

Printed on 100 % recycled paper





Form EXP - 4.2(b): Specific Construction  
Experience in Key Activities

**Key Activity No. (5)**

- a) Design and Construction of Administrative/Commercial Buildings having built up area of about 4000 sqm, including Complete Architectural, Structural, Mechanical, Electrical, Plumbing & Fire Fighting (ASMEP&F) works.

**STRABAG AG**

Project 1: ORBI Tower, Town Town

True Copy of the Completion Certificate







## TownTown Infra GmbH

Thomas-Klestil-Platz 13 1030 Wien  
 Tel: +43 1 531 23 71267  
 E-Mail: office@towntown.at  
 Web: [www.towntown.at](http://www.towntown.at)



Site area: 2,446 m<sup>2</sup>  
 Gross storey area  
 (over- and underground): 32,218,57 m<sup>2</sup>  
 Number of storeys: 31 (3 underground storeys, ground floor, 27 upper storeys)  
 Height: 102.5 m  
 Fully Developed office area: 20,380 m<sup>2</sup>  
 Special features: energy class A++  
 Building certification: ÖGNI (Austrian Sustainable Building Council) Platinum

**Main works:**

Excavation support: 1,710 m<sup>2</sup> intermittent bored pile wall with anchor horizon and shotcrete infilling  
 Foundation: combined pile and raft foundation system with 126 drilled piles  
 Earthworks: 17,400 m<sup>3</sup>  
 Concrete: 16,200 m<sup>3</sup>  
 Formwork: 65,000 m<sup>2</sup>  
 Reinforcement: 2,571 t  
 Façade: about 11.000m<sup>2</sup> element façade consisting of 2310 elements 145/330 cm  
 HVACs: concrete core activation, ventilation system, district heating and cooling, sprinkler system, plumbing, pressure ventilation system, building control system  
 Electrical installations: low voltage distribution, emergency power generator 1,500 kVA, fire alarm system, transformer station, server room  
 Conveyor technology: 6 Elevators and 1 façade maintenance unit  
 Interior construction: dry construction, flooring works, painting works, tiler works, tenant fit-outs, special request handling etc.

The ORBI Tower was built in accordance with the state of the art and in compliance with the legal safety standards, the relevant standards, rules and guidelines and the contractual provisions.

Strabag AG fulfilled the contract to our utmost satisfaction. All assigned works were performed on time, accurately and in a very high quality of execution.

The cooperation was professional and constructive at all times.

Kind regards

TownTown Infra GmbH

Matthias Waibel  
 Authorised Signatory



TRUE COPY

Dilip N. Salve  
 ADVOCATE & NOTARY

208 0320 M. S. CHS, Kannamwar Nagar  
 Tel: 022-26100000, 26100083



1686

FN 108564m ATU 01700106 ZIBIC edit Bank Austria BIC: BAWAAT33 BAN AT57 200 3100 1263 6046

Seite 2 von 2



Form EXP - 4.2(b): Specific Construction  
Experience in Key Activities

**Key Activity No. (5)**

- b) Design and Construction of Administrative/Commercial Buildings having built up area of about 4000 sqm, including Complete Architectural, Structural, Mechanical, Electrical, Plumbing & Fire Fighting (ASMEP&F) works.

**STRABAG AG**

Project 2: Pavilions Parliamentary





STRABAG AG

**STRABAG**

## Form EXP - 4.2(b)

## Specific Construction Experience in Key Activities

Date: 08<sup>th</sup> December 2021

Applicant's Legal Name: JV of STRABAG Infrastructure &amp; Safety Solutions GmbH and STRABAG AG

Applicant's Party Legal Name: STRABAG AG

IFB No.: MMRDA/ENG1/0002561

Page 01 of 02 pages

## Key Activity No. (5)

a) Design and Construction of Administrative/Commercial Buildings having built up area of about 4000 sqm, including Complete Architectural, Structural, Mechanical, Electrical, Plumbing & Fire Fighting (ASMEP&F) works.

Item	Information		
Contract Identification	Pavilions in the interim location of the Parliament		
Award Date	26 <sup>th</sup> April 2016		
Completion Date	2 <sup>nd</sup> May 2017		
Role in Contract	Prime Contractor		Management Contractor <input type="checkbox"/>
	Single entity <input checked="" type="checkbox"/>	JV member <input type="checkbox"/>	
Total Contract Amount	EUR 18.2 million		1 EURO = 1.1316 USD dated 26 <sup>th</sup> April 2016 and total contract amount in USD equivalent is 20.60 million
Description of the Works undertaken for demonstration of the similarity of the key activity	Design and Construction, including Complete Architectural, Structural, Mechanical, Electrical, Plumbing & Fire Fighting (ASMEP&F) works for the Parliamentary Administration building having total build up area of 3,450 sqm and gross floor area as 12,000 sqm.		
Employer's Name:	Republic of Austria — Parliamentary Administration		

STRABAG AG  
Ortenburgerstr. 27  
9800 Spittal an der Drau/Austria

Tel. +43 4762 620-640  
Fax +43 4762 620-788

Erste Group Bank AG  
IBAN. AT98 2010 04031093 6900  
BIC/SWIFT GIBAATWGXXX

Registered Office Spittal an der Drau, Landesgericht Klagenfurt, FN 61689w, VAT No. ATU14487107

Printed on 100 % recycled paper

STRABAG AG

**STRABAG**

Address:	Building Management & Infrastructure, Dr.-Karl-Renner-Ring 3, 1017 Vienna, Austria
Telephone/Fax Number:	Tel: +43 676 8900 2975
E-mail:	erich.schoefbeck@parlament.gv.at

- Attached is a true copy of the completion certificate or other similar document(s) for the contract / project issued by the client.

For STRABAG AG,

Printed Name:  
Designation:

Rajat Kumar Mishra  
Lawful Attorney



Manoj Kumar  
Lawful Attorney



**STRABAG AG**  
Ortenburgerstr 27  
9800 Spittal an der Drau/Austria

Tel +43 4762 620-640  
Fax +43 4762 620-788

Erste Group Bank AG  
IBAN AT98 2010 04031093 6900  
BIC/SWIFT GIBAA2WGXXX

Registered Office Spittal an der Drau, Landesgericht Klagenfurt FN 61689w VAT No. ATU14487107

Printed on 100 % recycled paper





Form EXP - 4.2(b): Specific Construction  
Experience in Key Activities

**Key Activity No. (5)**

- b) Design and Construction of Administrative/Commercial Buildings having built up area of about 4000 sqm, including Complete Architectural, Structural, Mechanical, Electrical, Plumbing & Fire Fighting (ASMEP&F) works.

**STRABAG AG**

Project 2: Pavilions Parliamentary

True Copy of the Completion Certificate



STRABAG AG  
 Directorate AP  
 Donau, City Strasse 9  
 1220 Vienna



REPUBLIK ÖSTERREICH

### REFERENCE LETTER

Pavilions parliamentary module construction

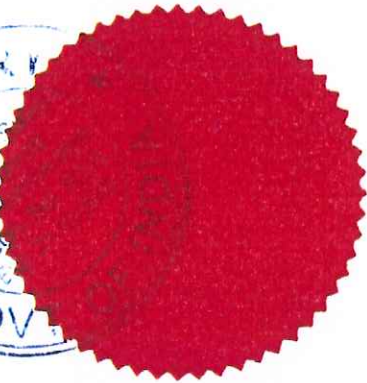

Dear Ladies and Gentlemen,

As the clients, we herewith confirm that the company STRABAG AG, with its registered seat at Ortenburger Strasse 27, 9800 Spittal an der Drau, Austria, performed the works for the project specified below in accordance with the terms of contract.

Project name:	Pavilions in the interim location of the Parliament
Place of the project:	Heldenplatz / Library Courtyard Dr. Karl-Renner-Ring 3, 1010 Vienna
Total order amount:	EUR 18.2 million
Order share:	100%
Project role:	General contractor
Execution period:	05/2016 - 04/2017
Date order placed:	04/26/2016
Date of handover / acceptance:	May 2nd, 2017
Contract form:	General contractor agreement
Project Manager:	Michael Schugerl
Construction manager:	Aljban Mamudi
Foreman:	Karl Falkensteiner

#### Project description:

Design and Construction, including Complete Architectural, Structural, Mechanical,



31 - Gebäudemanagement & Infrastruktur  
 Karl Renner Ring 1  
 1010 Wien, Österreich  
 +43 676 3900 293  
 info@schroetback.at





Electrical, Plumbing & Fire Fighting (ASMEP&F) works.

Built up area: approx. 3,450 m<sup>2</sup>

GFA (gross floor area): approx. 12,000 m<sup>2</sup>

Usable area: approx. 10,000 m<sup>2</sup>

SRI (gross volume): approx. 40,000 m<sup>3</sup>

The contracted works were performed punctually, to our full satisfaction, in accordance with the state of the art, and in compliance with the safety standards, the relevant prescriptions and contractual provisions.

Republic of Austria – Parliamentary Administration, legal successor of the Parlamentsgebauedesanierungsges.m.b.H. as the Client is satisfied with the performance of this project and the result of the works and confirms the satisfactory and constructive collaboration with STRABAG AG.

With kind regards.

Ing. Erich Schöfbeck  
Parliamentary Administration  
Head of Department  
8.4 Building Management & Infrastructure

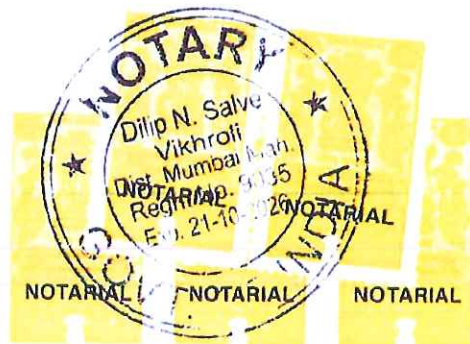

TRUE COPY

  
Dilip N. Salve  
ADVOCATE & NOTARY

233 9/20, Mar. 2nd, Kharanwar Nagar  
No. 12, Kharanwar, Mumbai - 400 083



Form EXP - 4.2(b): Specific Construction  
Experience in Key Activities

**Key Activity No. (5)**

- a) Design and Construction of Administrative/Commercial Buildings having built up area of about 4000 sqm, including Complete Architectural, Structural, Mechanical, Electrical, Plumbing & Fire Fighting (ASMEP&F) works.

Sub Contractor 2 – N A Construction Pvt Ltd

Project 1







N A Construction Pvt. Ltd.

**M/s. N A Construction Pvt. Ltd.**  
**Head Off. : 701, Headquarters,**  
**Sant Dnyaneshwar Marg,**  
**Opp. Chetana College, Bandra East,**  
**Mumbai 400 051.**  
**Email : [na\\_construction@rediffmail.com](mailto:na_construction@rediffmail.com).**  
**[na.construction@yahoo.in](mailto:na.construction@yahoo.in)**  
**Contact no. : 7034540728.**

**Form EXP – 4.2 (b)**  
**Specific Construction Experience in Key Activities**

Date: 10/12/2021

Bidder's Legal Name: JV of STRABAG Infrastructure &amp; Safety Solutions GmbH and STRABAG AG

Subcontractor Party Legal Name: N A Construction Pvt Ltd

IFB No MMRDA/ENG1/0002561

Page 01 of 01 pages

**Key Activity No. (5)**

(a) Design and Construction of Administrative/Commercial Buildings having built up area of about 4000 sqm, including Complete Architectural, Structural, Mechanical, Electrical, Plumbing & Fire Fighting (ASMEP&F) works.

Item	Information	
Contract Identification	Construction of Proposed Bus depot including all allied civil Structural, Electromechanical work on for Vasai Virar Municipal Transport at Yashwant Nagar, Virar West.	
Award Date	11 <sup>th</sup> May 2015	
Completion Date	31 <sup>st</sup> May 2019	
Role in Contract [check the appropriate box]	Prime Contractor	Management Contractor
	Single entity	
Total Contract Amount	INR. 46,56,97,921.70	USD. 72,79,260.00
Description of the Works undertaken for demonstration of the similarity of the key activity	RCC framed Administrative and Commercial Building including Complete Architectural, Structural, Mechanical, Electrical, Plumbing & Fire Fighting (ASMEP&F) works.	
Employer's Name:	Vasai Virar City Municipal Corporation	
Address:	Manvelpada Rd, Opp. Virar Police Station, Virar East, Virar, Maharashtra 401305.	
Telephone/Fax Number:	Phone: 0250 252 5105.	
E-mail:	E Mail ID - vasavirarcorporation@yahoo.com	

Attached is a true copy of the completion certificate or other similar document(s) for the contract/project issued by the client.

\* If the source of the exchange rate for the Bidder's proposed currency cannot be found in the Reserve Bank of India / State Bank of India, then the rate in the web site; [www.xe.com](http://www.xe.com) may be used. The date for the exchange rate shall be the Date of the contract.

For N A Construction Pvt. Ltd.

Authorised Signatory



Form EXP - 4.2(b): Specific Construction  
Experience in Key Activities

**Key Activity No. (5)**

- a) Design and Construction of Administrative/Commercial Buildings having built up area of about 4000 sqm, including Complete Architectural, Structural, Mechanical, Electrical, Plumbing & Fire Fighting (ASMEP&F) works.

Sub Contractor 2 – N A Construction Pvt Ltd

Project 1

True copies of Completion Certificate





मुख्य कार्यालय, विरार  
विरार (पूर्व),  
ता. वसई, जि. पालघर - ४०१ ३०५.



दूरध्वनी : ०२५० - २६२५१०१ / ०२/०३/०४/०५/०६

फॅक्स : ०२५० - २६२५१०९

ई-मेल : vasavirarcorporation@yahoo.com

गावक क्र. व वि.श.म./वांछा/४५४/२०२१

दिनांक : १५/०३/२०२१

### COMPLETION CERTIFICATE

1.	Name of the Work	: Construction of proposed Bus depot including all allied civil Structural, Electromechanical work on for Vasai Virar City Municipal Transport. (as item rate contract) at Yeshwant Nagar, Virar (w).
2.	Name of Contractor	: M/s NA CONSTRUCTION PVT LTD.
3.	Address of Contractor	: 701, Headquarters building sant Dyanashwar marg, opp.Chetana college, Bandra (E) Mumbai - 400052
4.	Work Order No. & Date	: Vvcmc/Transport/420 Dated 11/05/2015
5.	Tender Cost of Project	: Rs. 87,44,99,670/- (Restricted to Rs. 50,06,76,596/-)
6.	Actual cost executed	: Rs. 46,56,97,921.70 (excluding exccalation)
7.	Original completion priod	: 18 months
8.	Original Date of start	: 11/05/2015
9.	Date of completion	: 31/03/2019
10.	Actual Date of start	: 29/01/2016
11.	Breif Scope of work	: R.C.C. FRAMED ADMINISTRATIVE AND COMMERCIAL BUILDING 1) Construction builtup area 20,845.31sq.mt. 2) M.S. Liner pile 500 mm dia 625 nos of total 16503 mt. 3) Underground service bay for Bus repairing 4) Vehicular ramp from ground floor to second floor 5) second floor parking for car and two wheelers. 6) Double hight area for bus parking bay at ground floor of floor hight 8.25m. 7) Officers and other associated areas for administrative purpose shops, Restaurant banquet hall commercial purpose of floor height 4.30cm, 4.2 cm, 3.6m 8) Post tensioning slab from second floor to fifth floor
12.	Remarks	: Work completed satisfactorily

This completion Certificate is issued to M/s N.A. construction PVT Limited with on specific request without prejudice.

TRUE COPY  
GANESH DESAI  
& Co. L.  
NOTARY, MUMBAI  
MAHARASHTRA  
GOVT OF INDIA

City Engineer  
Vasai Virar City Municipal Corporation





ITEM NO.	DESCRIPTION OF ITEMS	UNIT	RATE	TOTAL QTY	Quantities of Major items executed:-			
					QUANTITIES AS PER FINANCIAL YEAR OF EXECUTION			
					2015-2016	2016-2017	2017-2018	2018-2019
1	Excavation in all Soil							
	Lift For 0.0 to 1.5 m	Cum	130.24	43.4	43.4	0	0	0
2	Excavation for foundation in Soft rock/old cement/lime fcls.							
	Lift For 0.0 to 1.5 m	Cum	295.74	1886.56	0	1886.56	0	0
	Lift For 1.5 to 3.0 m	Cum	309	298.32	0	298.32	0	0
	Lift For 3.0 to 4.5 m	Cum	315.88	0				
	Lift For 4.5 to 6.0 m	Cum	322.24	0				
3	Murum filling	Cum	307.91	2229.46	0	1430.57	0	798.89
4	Rubble soling 15 to 20 cm	Cum	952.4	1245.41	14.47	923.25	0	107.69
5	Rubble soling 80mm	Cum	730.98	362.39	0	274.67	0	87.72
6	M-30 R.C.C. cast in situ bored PILE . 500mm diameter	RMT	3310	16503.2	10544.5	5958.7	0	0
7	Chipping of Pile	NO	819.78	593	0	593	0	0
8	Bentonite slurry Treatment	RMT	262.54	16503.2	10544.5	5958.7	0	0
9	Chiseling Work	Ring Hour	1390.96	5269.83	3373.25	1896.58	0	0
10	PILE LOAD TEST	Nos	53432.02	7	4	3	0	0
11	Empty Boring	Rot	700	16263.6	10544.5	3719.1	0	0
12	REINFORCEMENT (CRS)	M.T	87723.96	1608.12	151.46	618.55	627.856	210.254
13	Taking trial bores for detailed investigations	Rmt	4246.18	105	105	0	0	0
14	Standard Penetration Test	Nos	289.38	7	7	0	0	0
15	Natural Moisture content	Per Test	233.2	4	4	0	0	0
16	Wet and Dry Density	Per Test	233.2	4	4	0	0	0
17	Sieve Analysis	Per Test	466.4	4	4	0	0	0
18	Liquid and Plastic Limit	Per Test	349.8	4	4	0	0	0
19	Shrinkage Limit	Per Test	349.8	4	4	0	0	0
20	Specific Gravity	Per Test	466.4	4	4	0	0	0
21	Unconfined Compressive Strength	Per Test	1049.4	4	4	0	0	0
22	Free Sweet Index	Per Test	466.4	4	4	0	0	0
23	pH Value	Per Test	466.4	4	4	0	0	0
24	Chloride (Cl)	Per Test	583	4	4	0	0	0
25	Sulphate (SO3)	Per Test	583	4	4	0	0	0
26	pH Value	Per Test	466.4	4	4	0	0	0
27	Chloride (Cl)	Per Test	583	4	4	0	0	0
28	Sulphate (SO3)	Per Test	583	4	4	0	0	0
29	Unconfined Compressive Strength	Per Test	1515.8	4	4	0	0	0
30	Dry Density	Per Test	466.4	4	4	0	0	0
31	Specific Gravity	Per Test	466.4	4	4	0	0	0
32	STRUCTURAL STEEL WORK							
	a) M.S Liner	M.T	98824.87	1127.92	720.41	407.51	0	0
	b) Structural works	M.T	79844.13	6.32	6.32	0	0	0
33	INTEGRITY TEST	RMT	712.306	16503.2	10544.5	5958.7	0	0
34	P.C.C WORKS							
35	M-15 P.C.C	Cum	7099.84	16503.2	36.18	494.741	0	0
36	R.C.C WORKS							
	M-30 R.C.C PILE CAP	Cum	9295.017	899.25	512.4	899.25	0	0
	M-30 R.C.C RAFT	Cum	9295.017	512.4	512.4	0	0	0
	M-30 R.C.C COLUMNS	Cum	9295.017	374.74	374.74	0	0	0



TRUE COPY  
 GANESH B. DESAI  
 NOTARY, MUMBAI  
 MAHARASHTRA  
 GOVT OF INDIA





ITEM NO.	DESCRIPTION OF ITEMS	UNIT	RATE	TOTAL QTY	Quantities of Major Items executed:-			
					QUANTITIES AS PER FINANCIAL YEAR OF EXECUTION			
39	M-30 R.C.C BEAMS	Cum	9295.017	1309.46	0	731	511.64	66.82
40	M-30 R.C.C PARDI	Cum	9295.017	235.25	0	61.7	125.8	47.75
41	M-30 R.C.C SLABS/LANDINGS	Cum	8469	1438.9	0	452.22	677.11	309.57
42	M-30 R.C.C WAIST SLAB	Cum	9295.017	205.59	0	113.18	70.21	22.2
43	M-30 R.C.C CHAJJA	Cum	9295.017	392.92	0	18.48	0	374.44
44	M-40 R.C.C FT SLABS AND BEAM	Cum	8767	3567.31	0	0	1701.05	866.26
45	POST TENSION HIGH TENSILE STEEL WIRE	M.T.	138838	32.712	0	0	22.594	10.118
46	BRICK MASONRY 190MM	Cum	5295	57.66	0	57.66	0	0
47	BLOCK MASONRY 300X200X150	Sqmt	1850	10214.91	0	0	2230.88	7994.03
48	INTERNAL PLASTER	Sqmt	189	19000	0	0	0	19000
49	WATER PROOFING	Sqmt	633.36	711.81	0	711.81	0	0
50	Galvalume iron Trapezoidal profiled sheet	Sqm	890	750.96	750.96	0	0	0
51	DISMANTLING BRICK WORK	cum	91.16	181.14	181.14	0	0	0
52	DISMANTLING RCC WORK	cum	396.44	1.62	1.62	0	0	0
53	EXCAVATION FOR ROADWAYS	Cum	131	1685.16	1685.16	0	0	0
54	PREPARING EMBANKMENT	Cum	244	792.6	792.6	0	0	0
55	Supplying 15 to 23mm. Rubble stone	Cum	385	383.625	383.625	0	0	0
56	Supplying Gravels 65	Cum	1430	103.38	103.38	0	0	0
57	Supplying Gravels 40 mm size	Cum	1570	64.11	64.11	0	0	0
58	Laying 15 to 23mm rubble voiding	Cum	145	383.625	383.625	0	0	0
59	Laying Gravels 65 mm size	Cum	55	103.88	103.88	0	0	0
60	Laying Gravels 40 mm size	Cum	55	64.11	64.11	0	0	0
61	Compacting Sub Grade	Sqmt	22	6400	6400	0	0	0
YEARWISE TOTAL AMOUNT OF WORK DONE					144,917,920.80	162,820,985.36	101,788,720.95	56,170,294.59

*M. Desai*  
 City Engineer  
 VVCMC



TRUE COPY  
*Ganesh B. Desai*  
 GANESH B. DESAI  
 & Co., LL.B  
 NOTARY, MUMBAI  
 MAHARASHTRA  
 GOVT OF INDIA

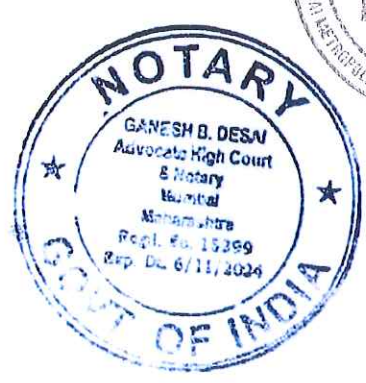

मुख्य कार्यालय विरार  
विरार (पूर्व),  
ता. वसई, जि. पालघर, पिन ४०१ ३०५.



दूरध्वनी : ०२५०-२५२५१०१/०२/०३/०४/०५/०६  
फॅक्स : ०२५०-२५२५१०७  
ई-मेल : vasairvirarcorporation@yahoo.com

जा.क्र. : वपिशम/बाँट/९४/२०१९  
दिनांक :- ०९/०७/२०१९

### COMPLETION CERTIFICATE

SR. NO.	DESCRIPTION	DETAILS
1)	Name of the work -	Construction of Proposed Bus depot including all allied civil Structural, Electromechanical work on for Vasai Virar Municipal Transport. (as item rate contract) at Yeshwant Nagar, Virar(w).
2)	Name of Contractor -	M/s.NA CONSTRUCTION PVT LTD.
3)	Address of Contractor -	701, Headqaurters building santDyaneshwarmarg opp. Chetana college bandra (E) Mumbai-400052
6)	Work Order & date -	VVCMC/TRANSPORT/420 Dated 11-05-2015
7)	Tendered cost of project -	Rs.87,44,99,670/- (Restricted to 50,06,76,596)
8)	Actual cost executed -	Rs.46,56,97,921.7 /-(excluding escalation -)
9)	Original completion period -	18 months.
10)	Original Date of start -	11/05/2015.
11)	Original date of completion -	10/11/2016. (Extension granted)
12)	Actual date of start -	29/01/2016
13)	Brief Scope of work -	<b>R.C.C FRAMED ADMINISTRATIVE AND COMMERCIAL BUILDING</b> 1)Construction Builtup area 20,845.31sqmt 2)M.S Liner pile 500 mm dia 625 nos of total 16503 rmt. 3)Underground service bay for bus repairing 4) Vehicular Ramp from Ground floor to Second floor 5) Second floor Parking for Cars and two wheelers 6)Double height area for Bus parking bay at ground floor of floor height 8.25 m 7)Offices and other associated areas for Administrative purpose, Shops, Restaurant, Banquet halls/Auditoriumfor commercial purpose of floor height 4.30m,4.20m,3.6m. 8)Post tensioning slab from second floor to Fifth floor
14)	Remarks -	Work completed satisfactorily.

This completion certificate is issued to M/s.NA construction PVT Limited with on specific request without prejudice.



*M. K. K.*  
CITY ENGINEER  
VVCMC





मुख्य कार्यालय, विरार  
विरार (पूर्व),  
ना. वसई, जि. ठाणे, पिन ४०१ ३०५.



दूरध्वनी ०२५०-२५२५१०१/०२/०३/०४/०५/०६  
फॅक्स ०२५०-२५२५१०७  
ई-मेल vasaivirarcorporation@yahoo.com

जा क व वि श म / ४३३/२०१५  
दिनांक ०३/०५/२०१५

To

M/s N.A. Construction Pvt. Ltd.,  
403, Om Palace, Harish Jain Chowk,  
Dr. Ambedkar Road,  
Khar West), Mumbai-400 052.

- Ref: 1) Letter of Acceptance no VVCMC/TRANSPORT/483/2015 dated 30/04/2015  
2) Performance security of **Rs.4, 37, 24,983/-** in the form of Bank Guarantee Receipt No. 69103332015050651096 Dated 06/05/2015 for One years drawn on Yes Bank, Andheri Branch.  
3) Contract Agreement Dated : 06/05/2015  
4) Transport committee Regulation No. 29, Dated : 29/04/2015

Dear Sir,

Pursuant to your furnishing the requisite security performance vide ref. no. 2 as stipulated in ITB Clause 44.1 and signing of the Contract for the construction of **"Construction of Proposed Bust Depot including Allied all civil, Structural and Electro Mechanical work on, for Vasai Virar Municipal Transport"** as the Item rate contract.

The accepted rates are enclosed and marked as Annexure 1.

You are requested to take possession of site and hereby instructed to proceed with the execution of the said works in accordance with the contract documents.

Yours Faithfully,

*(Signature)*

Deputy Municipal Commissioner  
Vasai Virar Municipal Transport



Form EXP - 4.2(b): Specific Construction  
Experience in Key Activities

**Key Activity No. (5)**

- b) Design and Construction of 8 Nos. of toll gates including complete Architectural, Structural, Mechanical, Electrical, Plumbing and Fire Fighting (ASMEP&F) works.

Sub Contractor 3 - Gajra Infra Pvt Ltd

Project 1







# GAJRA INFRA PRIVATE LIMITED

Office 1st Floor, Gajra Chambers, Mumbai-Agra Highway, Kamod Nagar, Nashik - 422 009  
Ph (0253) 2327468 / 69 Web gajraassociates.com

## Form EXP – 4.2 (b) Specific Construction Experience in Key Activities

Date: 09/12/2021

Bidder's Legal Name: JV of STRABAG Infrastructure & Safety Solutions GmbH and STRABAG AG  
Subcontractor Party Legal Name: GAJRA INFRA PRIVATE LIMITED

IFB No: MMRDA/ENG1/0002561

Page 1 of 2 pages

### Key Activity No.(5)

a) Design and Construction of **8 Nos. of toll gates** including complete Architectural, Structural, Mechanical, Electrical, Plumbing and Fire Fighting (ASMEP&F) works.

Contract with Similar Key Activities			
Item	Information		
Contract Identification	Hiwargaon pawsa and Chalakwadi Toll Plaza for Khed Sinner Expressway Pvt Ltd		
Award Date	14 <sup>th</sup> October 2015		
Completion Date	October 2016		
Role in Contract <i>[check the appropriate box]</i>	Prime Contractor		Management
	Single entity <input checked="" type="checkbox"/>	JV member <input type="checkbox"/>	Contractor <input type="checkbox"/>
Total Contract Amount	Rs 9,80,53,340/-		Subcontract or <input type="checkbox"/>
			USD 1,511,317/-*
Description of the Works undertaken for demonstration of the similarity of the key activity	Design and Construction of Toll Plaza Canopy and Toll Booths		
Employer's Name:	IL&FS Transportation Network Ltd		



Address:	IL&FS Financial Centre, Plot C-22,G Block, Bandra Kurla Complex, Mumbai-400051
Telephone/Fax Number:	+912226533333, +912226533295
E-mail:	NA

- Attached is a true copy of the completion certificate or other similar document(s) for the contract / project issued by the client.  
 \* Refer to ITA 13.2 for date and source of exchange rate.

Attached is a true copy of the completion certificate or other similar document(s) for the contract/project issued by the client.

**Project Consist of following subsystems**

Sub Systems	Compliances	Details
Design	Yes	Designing of the project was done with the help of Client
Construction	Yes	RCC, Brickwork, Plaster, building related finishing work and Steel structure.
Architectural	Yes	Design was done in coordination with client and approved by NHAI.
Structural	Yes	STADD related drawin8s were designed and submitted and approved by NHAI
Mechanical	Yes	All Mechanical related work was done by GIPL.
Electrical	Yes	All Electrical related work was done by GIPL.
Plumbing	Yes	Plumbing was done as per requirements of Client
Fire Fighting	Yes	Fire Fighting was done as per NBC specification
No of Lanes		





Form EXP - 4.2(b): Specific Construction  
Experience in Key Activities

**Key Activity No. (5)**

- b) Design and Construction of 8 Nos. of toll gates including complete Architectural, Structural, Mechanical, Electrical, Plumbing and Fire Fighting (ASMEP&F) works.

Sub Contractor 3 - Gajra Infra Pvt Ltd

Project 1

True copies of Completion Certificate



003741



# भारतीय राष्ट्रीय राजमार्ग प्राधिकरण

Telefax 0253 2372800  
e-mail nashik@nhai.org

( सडक परिवहन और राजमार्ग मंत्रालय )

## National Highways Authority of India

(Ministry of Road Transport & Highways)

Project Implementation Unit, Nashik

"Subodh House" S No. 911.2 Plot No-4 Behind Toyota Showroom

Off. Mumbai Agra Highway Nashik-422009 (MAHARASHTRA)

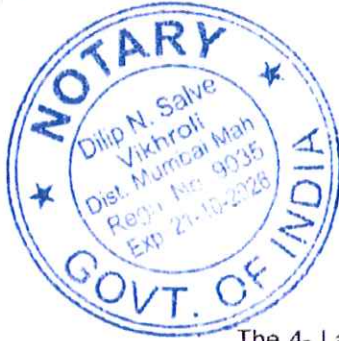

TO WHOM SO EVER IT MAY CONCERN

The 4- Laning of Khed – Sinnar section from Km 42.00 to 177.00 of NH-50 on DBFOT basis has been awarded by NHAI to M/s. Khed Sinnar Expressway Ltd. (M/s. IL & FS Transportation Networks Ltd.). The Concession Agreement has been signed on 08.05.2013 between NHAI and Concessionaire, M/s. Khed Sinnar Expressway Limited.

2. This is to certify that M/s Gajra Infra Private Ltd., 1<sup>st</sup> Floor, Gajra Chambers, Mumbai Agra Highway, Kamod Nagar, Nashik – 422009 has been appointed by the Concessionaire, M/s IL & FS Transportation Networks Ltd. for Architectural Design, Structural Design and Construction of Toll Plaza at two locations and Bus Shelters for Khed – Sinnar project stretch.

3. As per the records available with this office, this is to certify that M/s Gajra Infra Private Ltd. has executed and successfully completed the following works for "Four Lanning of Sinnar – Nashik section of NH-50 from Km 42+000 to Km 177+000 (Design Length – 137.946):

3.1. The Work Order Details are as follows:

- (i) Design and Construction of Toll Plaza Office Buildings, Construction of Secured Walkway and Landscaping of Toll Plaza area for an amount of Rs. 4,02,62,340/-.
- (ii) Design and Construction of Toll Plaza Canopy and Toll Booths for an amount of Rs. 3,50,16,000/-.
- (iii) Fabrication and Erection of Bus Shelters for an amount of Rs. 1,32,75,000/-.
- (iv) Construction of TMS foundations, Tunnel Stair Case and Miscellaneous Items for an amount of Rs. 95,00,000/-.



*(Handwritten Signature)*

Contd . . . . 2 . . . .



(134) 09.12.2016 KSEL - To whom so ever it may concern



Office No. G5 & G6 Sector - 10 Dwarka New Delhi - 110075

Phone: 31111111 Fax: 91-11-25080161, 25081460 Ext: 2223, 2318, 2468

1705



(2)

3.2. The Total value of the project work executed is Rs 9.80.53.340/- (Nine Crore Eighty Lakh Fifty Three Thousand Three Hundred and Forty Only) – Inclusive of all taxes. All above activities are Commissioned and in successful operation from October 2016 onwards.

3.3. The cited works have been executed as per the site requirement, sanctioned estimate and to the satisfaction of Concessionaire and NHAI.

4. This Certificate is issued on the request of Concessionaire in favour of M/s Gajra Infra Private Limited for the bidding purpose only. The details certified are referred from the available records and without any risk and liability on the part of NHAI.

Date: 10.12.2016  
Place: Nashik

  
(P. G. Khodaskar)  
GM(T) & Project Director  
PIU, Nashik

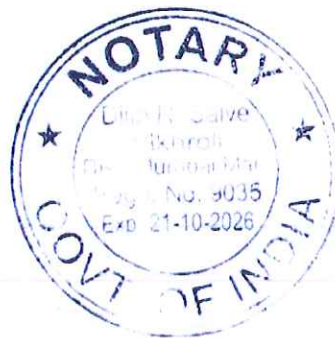
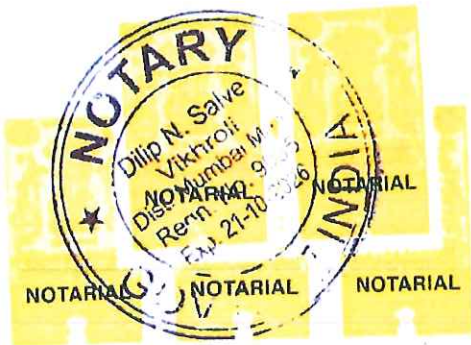

TRUE COPY  
  
Dilip N. Salve  
ADVOCATE & NOTARY  
238/920, Manas CHS, Kannamwar Nagar  
Mumbai - 400 083

(134) 09.12.2016 KSEL - To whom so ever it may concern



**IL&FS Transportation**

IL&amp;FS Transportation Networks Limited

IL&FS Financial Centre,	T	+91 22 2653 3333
Plot C-22, G Block,	F	+91 22 2653 3295
Bandra Kurla Complex,	W	www.inlindia.com
Mumbai - 400 051	CIN	L45203MH2000PLC129790
INDIA		

Work Order

ITNL- KSEL/PRJ/TEC/WOR-618/ 1539

Date: 14.10.2015

To,

M/s Gajra Infra Pvt Ltd,  
1<sup>st</sup> Floor, Gjra Chambers,  
Mumbai Agra Highway,  
Kamod Nagar, Nashik- 422009

Sub: Four Lanning of Khed-Sinnar Section of NH-50 from Km 42+000 to Km 177+000 in the state of Maharashtra on DBFOT Basis.

**Work Order for Design and Construction of Toll Plaza Canopy and Toll Booths- Reg**

Dear Sir,

With reference to your quotation and subsequent to our further negotiations, we are pleased to issue the Work Order to you for Architectural Design, Structural Design and Construction of Toll Plaza Office Buildings at Two Toll Plaza Locations for an amount of Rs. **3,50,16,000** in our project as per the enclosed scope of works and Terms and Conditions.

The work order is being issued in duplicate; one copy shall be returned duly signed by you as a token of your acceptance.

Regards

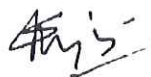

S P Singh  
Associate Vice President  
IL&FS Transportation Networks Limited  
Nashik

**ATTESTED**
  
 P. W. Joshi, Nashik



Terms and Conditions

Work Order No: ITNL/PRI/TEC/WOR-618/1539 dated: 14/10.2015.

**1. Scope of Work:**

- a. Submission of Design and Drawings: The general lay out plan of the Toll Plaza shall be provided by ITNL. You shall develop detailed Architectural Drawings including 3D views and Structural Design & Drawings for the Toll Plaza Canopy & Booths. The design and Drawings shall be submitted in 5 Sets of Hard Copies along with Soft Copy. You shall be responsible for attending to the queries raised by ITNL, the designers of IE and NHAI officials and comply with the observations and obtain the approval from IE/ NHAI.
- b. Construction: The scope covers construction of Toll Plaza Canopy & Toll Booths at Toll Plaza Locations at Ch: 91.106 and Ch: 138.749 and the scope covers the following:
- Construction of Toll Plaza Canopy as per the approved drawings complete in all respect.
  - Construction of Toll Booths complete in all respects as per the approved drawings.
  - Providing MS Spiral Stais for each Toll Booth
  - Construction of Bull Nose Barriers at the Toll Booth Islands.

General Material Specifications for the above works are enclosed herewith.

**2. Rate and Amount**

- The following rates have been agreed by you for construction of different buildings/ units:

SR.NO	ITEM	UNIT	No	AREA	RATE	AMOUNT
1	TOLL PLAZA CANOPY	Sq.m	4	7000	1025	2,87,04,000
2	Toll Booths with Protection Barriers	No	24		200000	48,00,000
3	M.S SPIRAL STAIRCASE	No	24	0	23000	5,52,000
4	BULL NOSE	No	24	-	40,000	9,60,000
<b>Total</b>						<b>3,50,16,000</b>

3. The above Rates and amounts are inclusive of all Taxes.

4. You shall furnish a Bank Guarantee towards Performance Security in the manner and format agreed by ITNL for an amount of 5% of the Contract Price and the same shall be valid till the end of maintenance period as mentioned below. Performance Bank Guarantee shall be released after successful completion works.

Project Office, Unit 101-105, Road Commercial Complex, Old Pune Naka, Solapur- 413002; Tel: 0217 2623202/3

ATTESTED  
 Dy. Executive Engineer  
 P W Deptt. Nashik

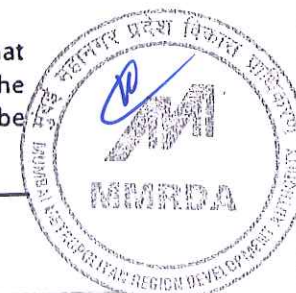

IL&amp;FS Transportation

IL&amp;FS Transportation Networks Limited

5. Inspection of Materials will be done at the work shop of the agency by ITNL Representative.

6. Payment Terms:

- a. An interest Free Mobilisation Advance of 20% of the Cost of Canopy works shall be paid against submission of valid Bank Guarantee for the same amount in the form and manner specified by ITNL.

A. For Canopy:

- |  |   |      |
|--|---|------|
| i. Delivery of Fabricated Materials at site                          | : | 50 % |
| (Mobilisation Advance if paid, shall be recovered from this payment) |   |      |
| ii. Completion of Erection of Structure                              | : | 20 % |
| iii. After completion of Roofing works.                              | : | 20 % |
| iv. After Completion of Works debris removal and handing over        | : | 10%  |

B. For Toll Booths:

- |  |   |     |
|--|---|-----|
| i. Delivery of fabricated structure at site      | : | 50% |
| ii. After Erection of Booth structure            | : | 30% |
| iii. After Completion of works and Certification | : | 20% |

C. For Spiral Stairs:

- |   |                            |
|---|----------------------------|
| o After fixing of fabricated stairs at site : | 100% cost of completed Nos |
|---|----------------------------|

D. For Bull Nose:

- |  |                            |
|--|----------------------------|
| o After Completion of each Bull Nose : | 100% cost of completed Nos |
|--|----------------------------|

7. Retention Money @ 5% shall be retained from each payment and the same shall be released after successful completion of the defect Liability period as mentioned in the next point.

8. Defect Liability Period: You shall be liable for maintenance of any defects to the works executed by you (other than damages due to external impacts etc) within 12 Months from the completion of total scope of works and releasing the Performance Security. Such maintenance shall be done solely at your cost and no extra claim shall be entertained to this account.

9. The commencement date shall be the date of issuing this Work Order and completion date shall be 120 days from the date of commencement/date of handing over the land for construction.

10. Payments shall not be made for any rejected or poor quality works.



Project Office: Unit 101, 105, Cross Road Commercial Complex, Old Pune Naka, Solapur- 413002 : Tel: 0217 2623202



By Executive Engineer  
P.W. Division, Solapur



1709



- 11. ITNL reserves the right to terminate the Contract at any time during the term of the Contract by giving One week notice if the progress of work and performance of the agency is not found satisfactory.
- 12. You shall be responsible to pay all taxes i.e, income tax, corporate tax , WCT, Sales Tax, VAT, Stamp Duty, Entry Tax, Customs and Import Duties, Octroi, Royalty for minerals, duty, labour cess etc imposed by various government authorities. You shall also submit the Form 407 & Form 408 (both the forms on quarterly basis).
- 13. You shall be responsible for compliances of all Labour laws, P.F. rules and other applicable statutory obligations.
- 14. You shall be responsible for total safety arrangements during all the works.

Thanking you,



SP Singh  
(Associate Vice President)  
IL&FS Transportation Networks Limited.

Terms and Conditions are accepted by me

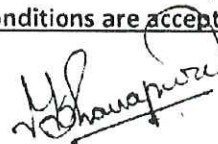

For M/s Gajra Infra Projects Pvt Ltd

ATTESTED

  
Dy. Executive Engineer  
P.W. Division, Nishik

003747

**IL&FS** Transportation

IL&FS Transportation Networks Limited

IL&FS Financial Centre	T	+91 22 2653 3333
PLOT C-22, G Block	F	+91 22 2653 3295
Bandra Kurla Complex	W	www.ilindia.com
Mumbai - 400 051	CIN	L45203MH2000PLC129790
INDIA		

Work Order

ITNL-KSEL /PRJ/TEC/WOR-618/ 1538

Date: 14<sup>th</sup> October, 2015

To,

**M/s Gajra Infra Pvt Ltd,**  
1<sup>st</sup> Floor, Gajra Chambers,  
Mumbai Agra Highway,  
Kamod Nagar, Nashik- 422009

Sub: Four Lanning of Khed-Sinnar Section of NH-50 from Km 42+000 to Km 177+000 in the state of Maharashtra on DBFOT Basis.

**Work Order for:**

1. Design and Construction of Toll Plaza Office Buildings,
2. Construction of Secured Walkway
3. Landscaping of Toll Plaza area-Reg

Dear Sir,

With reference to your quotation and subsequent to our further negotiations, we are pleased to issue the Work Order to you for Architectural Design, Structural Design and Construction of Toll Plaza Office Buildings at Two Toll Plaza Locations for an amount of Rs. **4,02,62,340** in our project as per the enclosed scope of works and Terms and Conditions.

The work order is being issued in duplicate; one copy shall be returned duly signed by you as a token of your acceptance.

Regards

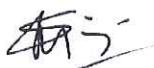

**S P Singh**  
Associate Vice President  
IL&FS Transportation Networks Limited  
Nashik

**ATTESTED**

  
Dy. Executive Engineer  
P.W. Division, Nashik



Page 1 of 4



Project Office "White House" Plot No. 5, Near ICICI Bank, 100 Feet Road, Behind ATM Union Bank of India, Indira Nagar, Nashik - 422 009 (Maharashtra)  
E-mail: [itnl@ilindia.com](mailto:itnl@ilindia.com) Ph: 0253-2396567 Fax: 0253-2396566

**1711**



Terms and Conditions

Work Order No: ITNL-KSEL /PRJ/TEC/WOR-618/ 1538 dated: 12<sup>th</sup> October, 2015.

**1. Scope of Work:**

- a. Submission of Design and Drawings: The general lay out plan of the Toll Plaza Complex along with the plan of the various building units shall be provided by ITNL. You shall develop detailed Architectural Drawings including 3D views and Structural Design & Drawings for all the Buildings at Toll Plaza, Secured Walkway, Landscaping etc. The design and Drawings shall be submitted in 5 Sets of Hard Copies along with Soft Copy. You shall be responsible for attending to the queries raised by ITNL, the designers of IE and NHAI officials and comply with the observations and obtain the approval from IE/ NHAI.
- b. Construction: The scope covers construction of Buildings, Secured Walkway and Landscaping in Toll Plaza at Toll Plaza Locations at Ch: 91.106 and Ch: 138.749 and the scope covers the following:
- Construction of all the Buildings as per the approved drawings complete in all respect including overhead tank ,Plumbing , electrification , drainage and sanitation arrangements like septic tank etc.
  - Construction of Secured Walk Way from Underground Tunnel to the Toll Admin Building as per the approved drawing.
  - Landscaping of total Toll Plaza area as per the agreed scheme and scope.
  - The general material and work specification of all the Building Works are enclosed herewith.

**2. Rate and Amount**

- The following rates have been agreed by you for construction of different buildings/ units:

Sr.No	Item	Unit	No	Area	Rate	Amount
1	Buildings.					
	Admin Building	Sqft	2	5430	1865	2,02,53,900
	Services Building	Sqft	2	1257	1780	44,74,920
	Back Up Building	Sqft	2	1499	1640	49,16,720
	Toilets	Sqft	2	837	3200	53,56,800
				<b>Subtotal-1</b>		<b>3,50,02,340</b>
2	Landscaping	Sqft	2	55000	36	39,60,000
3	Chain link Secured Walkway	No	2	1	650000	13,00,000
	<b>Total</b>					<b>4,02,62,340</b>



3. The above Rates and amounts are inclusive of all Taxes.
4. You shall furnish a Bank Guarantee towards Performance Security in the manner and format agreed by ITNL for an amount of 5% of the Contract Price and the same shall be valid till the end of maintenance period as mentioned below. Performance Bank Guarantee shall be released after successful completion works.
5. The rate for each building shall be firm for the complete work as mentioned above and the payment shall be for the actual quantities executed.
6. Inspection of Materials will be done at the work shop of the agency by ITNL Representative.
7. Payment Terms:
  - a. You shall raise Bills for the Quantity of works executed as per the below terms:

Building	Area ( Sq.Ft)	Stage Of Completion					Work Completion, Clearing Of Debris/ Materials Etc & Handing Over	Remarks
		Roof Slab	Brick Work	Plastering & Flooring	Painting, Door, Windows And Fixtures			
<b>Admin Building</b>								
Ground Floor	2221	12%	8%	8%	8%	-	Amount Proportionate To Area Of Each Floor	
First Floor	2221	12%	8%	8%	8%	-		
Second Floor	989	6%	4%	4%	8%	-		
<b>Total</b>	<b>5430</b>					<b>10 %</b>		
<b>Services Building</b>	<b>1257</b>	<b>30%</b>	<b>20%</b>	<b>20%</b>	<b>20%</b>	<b>10 %</b>	Single Floor	
<b>Back Up Building</b>	<b>1499</b>	<b>30%</b>	<b>20%</b>	<b>20%</b>	<b>20%</b>	<b>10 %</b>	Single Floor	
<b>Toilets</b>	<b>837</b>	<b>20%</b>	<b>20%</b>	<b>20%</b>	<b>20%</b>	<b>10 %</b>	Single Floor	

- b. Payment for Secured Walkway and Landscaping shall be as per actual scope of works.
  - c. Bills for the completed works shall be certified by ITNL representatives.
8. Retention Money @ 5% shall be deducted from each R.A. Bill and shall be released after completion of the defect Liability period as mentioned in SI No: 9.

Page 3 of 4

ATTESTED

Dy. Executive Engineer  
P.W. Division

1713





9. Defect Liability Period: You shall be liable for maintenance of any defects to the works executed by you (other than damages due to external impacts etc) within 12 Months from the completion of total scope of works and Handing over. Such maintenance shall be done solely at your cost and no extra claim shall be entertained to this account.
10. The commencement date shall be the date of issuing this Work Order and completion date shall be 120 days from the date of commencement/date of handing over the land for construction.
11. Payments shall not be made for any rejected or poor quality works.
12. ITNL reserves the right to terminate the Contract at any time during the term of the Contract by giving One week notice if the progress of work and performance of the agency is not found satisfactory.
13. The agency shall be responsible for compliances of all Labour laws, P.F. rules and other applicable statutory obligations.
14. You shall be responsible to pay all taxes i.e, income tax, corporate tax , WCT, Sales Tax, VAT, Stamp Duty, Entry Tax, Customs and Import Duties, Octroi, Royalty for minerals, duty, labour cess etc imposed by various government authorities. You shall also submit the Form 407 & Form 408 (both the forms on quarterly basis).
15. You shall be responsible for total safety arrangements during all the works.

Thanking you,



SP Singh

(Associate Vice President)  
IL&FS Transportation Networks Limited.

Terms and Conditions are accepted by me

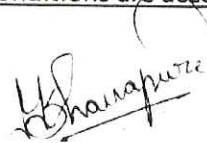

For M/s Gajra Infraprojects Pvt Ltd

**ATTESTED**

  
Dy. Executive Engineer  
P.W. Division, Nashik



## IL&amp;FS Transportation Networks Limited

41 S. Financial Centre	T: +91 22 2653 3333
Plot C 22, G Block	F: +91 22 2653 3295
Bandra Kurla Complex	W: www.ilandfs.com
Mumbai - 400 051	CIN: L45203MH2000PLC129790
INDIA	

Work Order

IINI-PRJ/TEC/WOR-618/1333

Date: 6<sup>th</sup> July, 2015

To,

**M/s Gajra Infra Pvt Ltd,**1<sup>st</sup> Floor, Gajra Chambers,

Mumbai Agra Highway,

Kamod Nagar, Nashik- 422009

Sub: Four Lanning of Khed-Sinnar Section of NH-50 from Km 42+000 to Km 177+000 in the state of Maharashtra on DBFOT Basis.

Work Order for Fabrication and Erection of Bus Shelters - RegRef : Your Quotation dated 6<sup>th</sup> June 2015

Dear Sir,

With reference to your quotation dated 6<sup>th</sup> June, 2015 and subsequent to our further negotiations, we are pleased to issue the Work Order to you for Fabrication and Erection of Bus Shelters for an amount of Rs. **1,32,75,000.00** in our project as per the enclosed scope of works and Terms and Conditions.

The work order is being issued in duplicate: one copy shall be returned duly signed by you as a token of your acceptance.

Regards

**S P Singh**

Associate Vice President,

IL&amp;FS Transportation Networks Limited,

Nashik.

Encl : Terms and Conditions



Page 1 of 3





Terms and ConditionsWork Order No: ITNL PRJ ITC WOR-618-1333 dated Date: 6<sup>th</sup> July, 2015.**I. Scope of Works and & Cost:**

Sl	Description	Unit	Tentative Qty	Rate Rs.	Amount Rs.
1	<ul style="list-style-type: none"> <li>• Fabrication of Bus Shelter as per the enclosed Drawing</li> <li>• Transportation to Site</li> <li>• Civil Works for Foundation, Plinth, etc.</li> <li>• Fixing/ Erection of Bus Shelter at specified locations.</li> <li>• Painting if any as per approved Colour Scheme.</li> <li>• Fixing of Boards/Sheet for Advertising</li> <li>• Fixing of Stainless Steel Dust Bins</li> <li>• Fixing of Stainless Steel sheet moulded Seat</li> <li>• Flooring with Concrete Tiles. ( Road Side Kerb and Earth Filling excluded)</li> </ul>	No	45	295000.00	1,32,75,000.00

2. The above Rates are inclusive of all Taxes.
3. The quantity as mentioned above is tentative and is subject to increase or decrease. However, the rate shall remain firm
4. You shall furnish a Bank Guarantee towards Performance Security in the manner and format agreed by ITNL for an amount of 5% of the Contract Price and the same shall be valid till the end of maintenance period as mentioned below. Performance Bank Guarantee shall be released after successful completion works.
5. The contract price shall be for the complete work as mentioned above and no extra amount shall be paid.
6. Inspection of Materials will be done at the work shop of the agency by ITNL Representative.
7. Payment Terms:

You shall raise Bills for the Quantity of works executed as per the below terms:

- a) 60% amount shall be released for the No. of Bus Shelter fabricated.

Page 2 of 3



Project Office: "White House", Plot No. 5, Near ICICI Bank, 100 Feet Road, Behind ATM Union Bank of India, Ind...

Nashik - 422 009 (Maharashtra)  
Email: [theoffice@gmail.com](mailto:theoffice@gmail.com) Ph: 0253-2396567 Fax: 0253-2396566

- b) Balance 40% shall be released after completion of fixing of bus shelters in all respect.
- c) The relevant and applicable taxes shall be deducted from your R.A. Bills as per prevailing rules and regulations.
- d) You shall comply with all the applicable statutory taxation obligations and submit applicable forms/certificates in support of the compliances as and when demanded by us.
8. Retention Money @ 5% shall be deducted from each R.A. Bill and shall be released after completion of the defect Liability period as mentioned in SI No: 8.
9. Defect Liability Period: You shall be liable for maintenance of any defects to the works executed by you (other than damages due to external impacts etc) within 12 Months from the completion of total scope of works and releasing the Performance Security. Such maintenance shall be done solely at your cost and no extra claim shall be entertained to this account.
10. The commencement date shall be Ten Days from the date of signing of this Work Order and completion date shall be 30 days from the date of handing over the respective locations at site for the work.
11. Payments shall not be made for any rejected or poor quality works.
12. ITNL reserves the right to terminate the Contract at any time during the term of the Contract by giving One week notice if the progress of work and performance of the agency is not found satisfactory.
13. You shall be responsible for compliances of all Labour laws, P.F. rules and other applicable statutory obligations.
14. You shall be responsible for total safety arrangements during all the works.

Thanking you,

**Terms and Conditions are accepted by me**



**S P Singh**  
Associate Vice President,  
IL&FS Transportation Networks Limited,  
Nashik

For M/s Gajra Infra Pvt Ltd





IL&amp;FS Transportation Networks Limited

IL&FS Financial Centre T: +91 22 2653 3333  
 Plot D-22, 3 Block F: +91 22 2652 3979  
 Bandra Kurla Complex W: www.ilindia.com  
 Mumbai 400 051 CIN: U45203MH2000PLC129796  
 NDA

### Work Order

ITN-FSELL/PRJ/TEC/WOR-618/2017

Date: 13/12/2017

To,

**M/s Gajra Infra Pvt Ltd,**  
 1<sup>st</sup> Floor, Gajra Chambers,  
 Mumbai Agra Highway,  
 Kamod Nagar, Nashik- 422009

Subject : Four laning of Fagne – Maharashtra / Gujarat Border section of NH-6 from Km. 510.000 to Km. 650.794 in the state of Maharashtra to be executed on BOT (Toll) basis on DBFOT pattern under NHDP Phase IV-  
**Work Order for Construction of Bus Shelters - Reg**

Ref : Your Quotation dated 13<sup>th</sup> Dec 2017

Dear Sir,

With reference to the referred quotation and subsequent further negotiations, we are pleased to issue the Work Order to you for construction of Bus shelters including Fabrication and Erection for an amount of Rs. 94,50,000/- in our project as per the enclosed BOQ and Terms and Conditions.

The work order is being issued in duplicate; one copy shall be returned duly signed by you as a token of your acceptance.

Regards

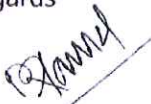
  
 M. Kamalpathy  
 Vice President

Encl : Terms and Conditions



Work Order No: ITNL-FSEL/PRJ/TEC/WOR-618/

Date: 15/04/2018

**A. BOQ**

SI	Description	Unit	Tentative Qty	Rate Rs.	Amount Rs.
1	<ul style="list-style-type: none"> <li>• Fabrication of Bus Shelter as per the enclosed Drawing</li> <li>• Transportation to Site</li> <li>• Civil Works for Foundation, Plinth, etc.</li> <li>• Fixing/ Erection of Bus Shelter at specified locations.</li> <li>• Painting if any as per approved Colour Scheme.</li> <li>• Fixing of Boards/Sheet for Advertising</li> <li>• Fixing of Stainless Steel Dust Bins</li> <li>• Fixing of Stainless Steel sheet moulded Seat.</li> <li>• Flooring with Concrete Tiles.</li> <li>• Road Side Kerb, Ramp for disabled (Earth Filling excluded)</li> </ul>	No	36	262500	9450000

**B. Terms and Conditions**

1. The above Rates are including all Taxes except GST (12%) which shall be paid extra.
2. The quantity as mentioned above is tentative and is subject to increase or decrease. However, the rate shall remain firm
3. You shall furnish a Bank Guarantee towards Performance Security in the manner and format agreed by ITNL for an amount of 5% of the Contract Price and the same shall be valid till the end of maintenance period as mentioned below. Performance Bank Guarantee shall be released after successful completion works.
4. The contract price shall be for the complete work as mentioned above and no extra amount shall be paid.
5. Inspection of Materials will be done at the work shop of the agency by ITNL Representative.
6. Payment Terms:

You shall raise Bills for the Quantity of works executed as per the below terms:

- a) 60% shall be released for the No. of Bus Shelter fabricated.





- b) Balance 40% shall be released after completion of fixing of bus shelters in all respect.
- c) The relevant and applicable taxes shall be deducted from your R.A. Bills as per prevailing rules and regulations.
- d) You shall comply with all the applicable statutory taxation obligations and submit applicable forms/certificates in support of the compliances as and when demanded by us.
7. Retention Money @ 5% shall be deducted from each R.A. Bill and shall be released after completion of the defect Liability period as mentioned in SI No: 8.
8. Defect Liability Period: You shall be liable for maintenance of any defects to the works executed by you (other than damages due to external impacts etc) within 12 Months from the completion of total scope of works and releasing the Performance Security. Such maintenance shall be done solely at your cost and no extra claim shall be entertained to this account.
9. The commencement date shall be from the date of signing of this Work Order and completion date shall be 30 days from the date of handing over the respective locations at site for the work.
10. Payments shall not be made for any rejected or poor quality works.
11. ITNL reserves the right to terminate the Contract at any time during the term of the Contract by giving One week notice if the progress of work and performance of the agency is not found satisfactory.
12. You shall be responsible for compliances of all Labour laws, P.F. rules and other applicable statutory obligations.
13. You shall be responsible for total safety arrangements during all the works.

  
**M. Kamalapathy**  
 Vice President



**Terms and Conditions are accepted by me**

*Received  
Gajra*

For M/s Gajra Infra Pvt Ltd



Sl. No.	DESCRIPTION	SIZE	MATERIAL
1	MAIN VERTICAL COLUMNS	DD:200MM X 155VG	S.S. 304
2	BACK SUPPORT PIPE	DD:75MM X 175VG	S.S. 304
3	BENCH SUPPORT PIPE	DD:150MM X 155VG	S.S. 304
4	ROOF SUPPORT PIPE	DD:200MM X 155VG	S.S. 304
5	ROOF SUPPORT PLATES	25MM THK	S.S. 304
6	ADV. BOARD OUTER FRAME (SIDE)	100X40X185VG	S.S. 304
7	ADV. BOARD INNER FRAME (SIDE)	25X25X185VG	M.S./G.I.
8	ADV. BOARD COLUMNS (SIDE)	DD:150MM X 155VG	S.S. 304
9	ADV. BOARD FRAME (MAIN)	25X25X185VG	M.S./G.I.
10	RAILING	DD:75MM X 175VG	S.S. 304
11	RAILING COLUMNS	DD:50MM X 185VG	S.S. 304

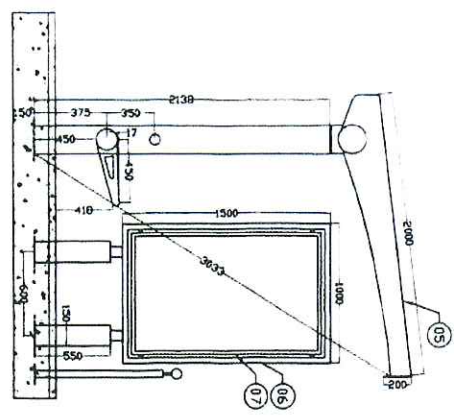

L.H. SIDE VIEW

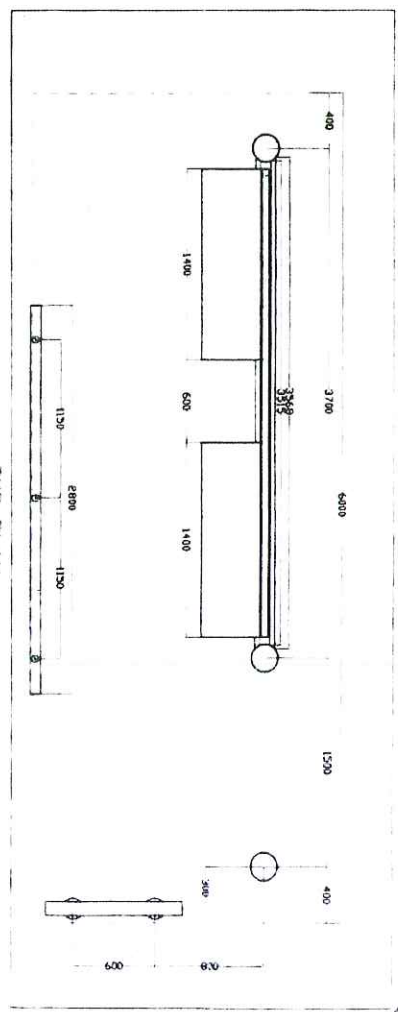

TOP PLAN

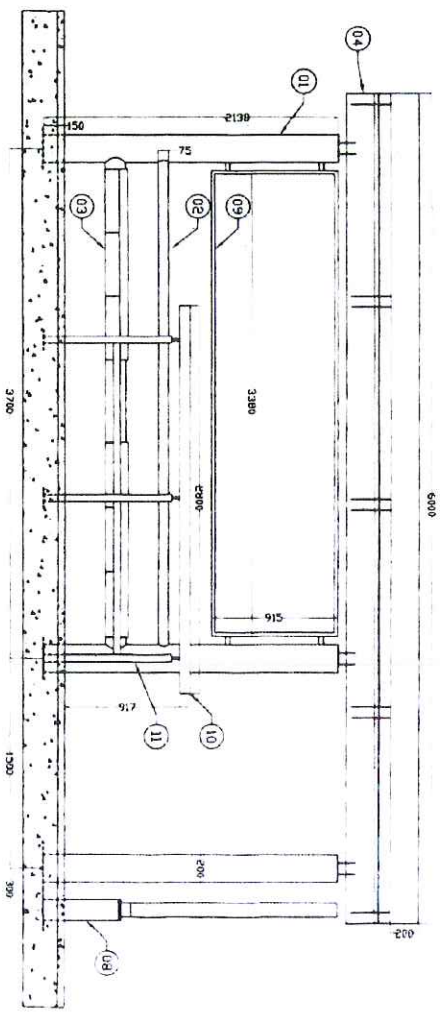

FRONT ELEVATION

**NATIONAL HIGHWAYS AUTHORITY OF INDIA**

4th Floor, 1st Gate, Naraina, New Delhi - 110028

Section of the structure in the side of Naraina to be executed as per the plan of the project under the title mentioned.

PROJECT CONTRACTOR

1. M/s. SPS&S

2. M/s. SPS&S

3. M/s. SPS&S

4. M/s. SPS&S

5. M/s. SPS&S

6. M/s. SPS&S

7. M/s. SPS&S

8. M/s. SPS&S

9. M/s. SPS&S

10. M/s. SPS&S

11. M/s. SPS&S

DESIGNER

M/S. Infrastructure

1st Floor, Naraina, New Delhi - 110028

DATE

DATE

DATE

DATE

DATE

DATE

DATE

DATE

DATE

DATE





Form EXP - 4.2(b): Specific Construction  
Experience in Key Activities

**Key Activity No. (5)**

- b) Design and Construction of 8 Nos. of toll gates including complete Architectural, Structural, Mechanical, Electrical, Plumbing and Fire Fighting (ASMEP&F) works.

Sub Contractor 3 - Gajra Infra Pvt Ltd

Project 2





# GAJRA INFRA PRIVATE LIMITED

Office : 1st Floor, Gajra Chambers, Mumbai-Agra Highway, Kamod Nagar, Nashik - 422 009  
Ph : (0253) 2327468 / 69, Web : gajraassociates.com

## Form EXP – 4.2 (b) Specific Construction Experience in Key Activities

Date: 09/12/2021

Bidder's Legal Name: JV of STRABAG Infrastructure & Safety Solutions GmbH and STRABAG AG

Subcontractor Party Legal Name: GAJRA INFRA PRIVATE LIMITED

IFB No.: MMRDA/ENG1/0002561

Page 01 of 02 pages

### Key Activity No.(5)

a) Design and Construction of 8 Nos. of toll gates including complete Architectural, Structural, Mechanical, Electrical, Plumbing and Fire Fighting (ASMEP&F) works.

Contract with Similar Key Activities			
Items	Information		
Contract Identification	Raikal Toll Plaza for Jadcherla Expressways Pvt Ltd		
Award Date	5 <sup>th</sup> June 2017		
Completion Date	May 2019		
Role in Contract [check the appropriate box]	Prime Contractor	Management Contractor	Subcontractor
	Single entity <input checked="" type="checkbox"/>	JV member <input type="checkbox"/>	<input type="checkbox"/>
Total Contract Amount	Rs 29,50,00,000/-	USD 4,584,340/-*	
		* considering exchange rate as on 5 <sup>th</sup> June, 2017 at the rate of 64.3495 from <a href="https://www.xe.com">https://www.xe.com</a>	
Description of the Works undertaken for demonstration of the similarity of the key activity	Construction of permanent toll plaza and admin structure for 12 lanes		
Employer's Name:	Ashoka Buildcon Ltd		



Roshan





Address:	Sr No 861 Ashoka House, Ashoka Marg, Wadala, Nashik 422011
Telephone/Fax Number:	+912533011705, +912532236704
E-mail:	NA

- Attached is a true copy of the completion certificate or other similar document(s) for the contract / project issued by the client.  
\* Refer to ITA 13.2 for date and source of exchange rate.

Attached is a true copy of the completion certificate or other similar document(s) for the contract/project issued by the client.

**Project Consist of following subsystems**

Sub Systems	Compliances	Details
Design	Yes	Designing of the project was done with the help of Client
Construction	Yes	RCC, Brickwork, Plaster, building related finishing work and Steel structure.
Architectural	Yes	Design was done in coordination with client and approved by NHAI.
Structural	Yes	STADD related drawings were designed and submitted and approved by NHAI
Mechanical	Yes	All Mechanical related work was done by GIPL.
Electrical	Yes	All Electrical related work was done by GIPL.
Plumbing	Yes	Plumbing was done as per requirements of Client
Fire Fighting	Yes	Fire Fighting was done as per NBC specification
No of Lanes	12	



Form EXP - 4.2(b): Specific Construction  
Experience in Key Activities

**Key Activity No. (5)**

- b) Design and Construction of 8 Nos. of toll gates including complete Architectural, Structural, Mechanical, Electrical, Plumbing and Fire Fighting (ASMEP&F) works.

Sub Contractor 3 - Gajra Infra Pvt Ltd

Project 2

True copies of Completion Certificate







Ashoka Buildcon Limited



Date: 20<sup>th</sup> May 2019

To,

GAJRA INFRA PVT. LTD.,  
1<sup>st</sup> Floor, Gajra Chambers,  
Mumbai Agra Highway, Kamod Nagar,  
Nashik- 422009

Subject: Turnkey works for construction of permanent Toll Plaza and Admin Structure for 12 Lanes at km- 53.94 Truck Lay Bay partially at km- 53.94 and partially at km-72 and final completion certificate- Confirmation of work done for tendering purpose-Reg.

Reference:- Your Telephonic discussion dated 18<sup>th</sup> May 2019

Dear Sir,

This has reference to your telephonic discussion dated 18<sup>th</sup> May 2019 regarding your requirement of confirming work done by you at our subject mentioned project; this is to confirm that you have executed the work amounting to Rs.29,50,00,000/- (In words Twenty Nine Crore Fifty Lakhs Only) successfully as per revised contract.

Above certification is issued for the tendering purpose only as per your request

Yours Faithfully

For, Ashoka Buildcon Limited

S.P. Ingle  
Authorised Signatory

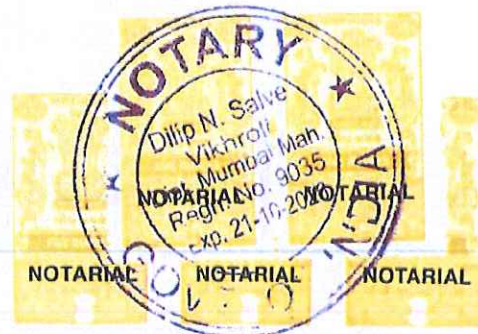

TRUE COPY

Dilip N. Salve  
ADVOCATE & NOTARY

238 9320, Manoj CHS, Kannamwar Nagar  
No. 2, Vikhroli, Mumbai - 400 083.





Ashoka Buildcon Limited

Date: -5<sup>th</sup> June 2017

To,  
Gajra Infra Pvt Ltd.  
1<sup>st</sup> Floor, Gajra Chambers, Mumbai-Agra Highway,  
Kamod Nagar, Nashik - 422009  
Maharashtra, India,

Kind Attention: Mr. Hemant Parakh

**Sub:** -Work order for "Construction of Permanent Toll Plaza and Admin Structure for 12 lanes at km - 53.940, Truck Lay bay Partially at Km. - 53.940 and partially at Km. - 72.00, and Final Completion Certificate Works".

Dear Sir,

With reference to the above mentioned subject and our subsequent discussion we had with you, we are pleased to place our order for "Construction of Permanent Toll Plaza and Admin Structure for 12 lanes at km - 53.940, Truck Lay bay Partially at Km. - 53.940 and partially at Km. - 72.00, and Final Completion Certificate Works" for Contract Price amounting **Rs. 30,98,00,000/- (In Word Rupees Thirty Crores Ninety Eight Lakhs Only)** with all inclusive.

#### Project Site Data

You have inspected & examined the Project site and its surroundings and to have satisfied himself before entering into this contract, as to:

1. The form & the nature of the Project site;
2. the hydrological & climatic conditions;
3. the extent and the nature of the Works and Plant & materials necessary for the execution and the completion of the works and the remedying of any defects;
4. the means of access to the project site and the accommodation the subcontractor may require;

All other factors and circumstances affecting the Subcontractor's rights and obligations under the Contract Price and Time for Completion.

#### TERMS & CONDITIONS:-

1. Scope of the Work - "Construction of Permanent Toll Plaza and Admin Structure for 12 lanes at km - 53.940, Truck Lay bay Partially at Km. - 53.940 and partially at Km. - 72.00, and Final Completion Certificate Works" for Contract Price amounting **Rs. 30,98,00,000=00 (In Word Rupees Thirty Crores Ninety Eight Lakhs Only)** with all inclusive taxes, duties, levies, labour charges, fuel, oil, lubricants, transportation, equipment, tools & tackles, safety apparatus, supervision, overheads, profits and /or any other incidentals required for the execution of this contract. Since the work is Infra Structure work, Service Tax is not applicable as per norms.



Regd. Office



Page - 1 - of 5

Ashoka Ming, Vardola, Nashik-422 011, Maharashtra, India • Tel: +91 214 251 1705  
www.ashokabuildcon.com







Ashoka Buildcon Limited

The above Lump-Sum Cost shall comprise of Construction of Permanent Toll Plaza and Admin Structure for 12 lanes at km - 53.940, Truck Lay bay Partially at Km. - 53.940 and partially at Km. - 72.00, and Final Completion Certificate Works. The offer includes entire Execution, handing over possession of the completed work and rectification of defects if any during the defects liability period.

Detail Scope of work & Mode of Measurement for admin structure is as per **attached Annexure-I**.

2. The awarded works should be completed within 11 months from the date of commencement of work. The date of Commencement of work is 10<sup>th</sup> June 2017.
3. Before commencement of work, Contractor shall have to submit construction programme to Employer (ABL).
4. Contractor should design, construct the Project in accordance with the Project Requirements; make its own arrangements for construction materials and observe and fulfill the environmental, safety and other requirements under the Applicable Laws and Applicable Permits. All designs & drawings to be submitted to ABL for approval of I.E. Design limited to building & canopy structure is in scope of contractor.
5. Contractor will be responsible for quality, soundness, durability, any safety and the overall Project Requirements notwithstanding the appointment by it of any Subcontractors to design and Execute the Works.
6. The Contractor should provide the all types of manpower and sufficient machineries required to complete the scope of wok described in T&C - I and modify whenever deemed necessitated by Employer.
7. Employer (ABL) will provide only the land for Labour camp, site office, store and construction material and machinery. Construction of labour camp + erection/ execution of the same have to be done by you (Contractor). You shall arrange water and electricity for your staff and for execution works.
8. The contractor promptly comply all provisions of Labour Laws, Acts and Rules as applicable to these works and safety rules and regulations of the project and enforce the same on all workmen, the provisions of the Employees Provident Funds and Miscellaneous Provision Act 1952 (latest revision) and schemes framed there under, in so far they are applicable to this Project.
9. **Extra Items:** Any item which is not covered under scope of the Contractor shall be considered as extra item and the payment shall be on basis of applicable SOR rate, in case the rate is not mentioned in SOR the rate for that items shall be consider as material cost + labour cost + cost of Plant & Machinery + 15% to cater for profit and overheads, and the same shall be certified by the Director of the Employer. The final rates shall be decided on mutually agreed basis. No escalation shall be paid for such extra items.
10. It is explicitly understood that you have acquainted yourself with site conditions, surrounding and no extra will be paid for any incorrect assumption of site condition.
11. All works shall be carried out as per approved drawings and as per MORI&H (fourth revision), Four Lining Manual for highways through PPP, IRC, Indian Standard Specifications and codes and or as per customers specification, which will be verified by site engineer periodically.
12. The work should be carried out with due diligence & subject to approval of the D.H. (L.Q.A.) of ABL.

Regd Office S No 861 Ashoka House Ashoka Marg Vadala Nashik 422 011 Maharashtra, India Tel : +91 253 3011705  
F ax +91 253 2236704 www.ashokabuildcon.com

CIN L45200MH1993PLC01/1970

Page - 2 - of 5



*[Handwritten signature]*







Ashoka Buildcon Limited

13. The quantity of work executed shall be measured monthly.
14. The work shall not be deemed to be completed until you have obtained satisfactory completion certificate from Project Director ABL.
15. You will ensure that all your workers strictly observe the security rules and regulations and pass system / entry passes wherever applicable. The security of your materials as well as the materials if any issued to you by the ABL will be your responsibility. In case of loss, theft, fire etc. of ABL's material the same shall be recovered from your dues payments / retention money or any other mode.
16. You will follow all safety rules and regulations applicable to project. As soon as if any accident happens to any of his workmen you will submit to the D.H.(E.Q.A.) of ABL the details regarding the workman and all the relevant data required to fill up the reports as required by ESIC / or any other Insurance Company and take further necessary action. This information should be submitted to the Site office of the ABL by you only. Failure to do so may entitle the D.H. (E.Q.A.) of ABL to withhold any dues or suspend the work that is being carried out by you. You will not employ the injured workman unless a fitness certificate from authorized Medical Officer is produced by the workman and submitted to the ABL's Site office. You will be taking necessary precautions for the safety of labours and the project facility during execution at the site and guard your work as per specified required norms.
17. Contractor shall comply with all environmental requirements stipulated in the Project Requirements and with all environmental laws and regulations applicable to the Project, including but not limited to standards for noise and vibration levels and airborne and waterborne pollutants. Regulations shall be understood to include, but are not limited to, any environmental report approved for the Project. In the event of conflict or inconsistency among the standards stipulated in applicable laws and regulations and those stipulated in this Agreement, the more stringent of such standards shall apply.
18. Contractor shall ensure the minimum width of trafficable road equal to the Existing Road under the scope of Works of the Contractor, at all times open for public use and from the date of issue of the Notice to Proceed shall not act in any way which will hinder the Project Company in its obligation to keep open the Existing Road under the scope of Works of the Contractor.
19. Where it is necessary that operations required for the Execution of the Works or any part thereof interfere with the use or occupation of any public or private roads or footpaths the Contractor shall, before it commences such operations, apply for and obtain the written approval therefore from the competent statutory authority or the permission of the person affected, as the case may be, and shall observe all the requirements that the statutory authority may impose in relation thereto and take all the necessary measures in order to be allowed to interfere with any public or private roads or footpaths.
20. Contractor will be responsible to facilitate or support for all pre-construction activities including tree cutting, encroachment removal wherever feasible, relocation of obstructing religious structures, graveyards and any other sensitive receptors for the Project. All necessary actions/permits/approvals from relevant authorities to be taken by you and to be informed to ABL. Prime responsibility shall be of ABL.
21. The contractor shall be responsible for procuring all insurance cover regarding workmen, materials, fire, theft, Transit insurance for men and materials, CAR etc. and submit the copy of insurance policy to the Employer for records.
22. You shall carry out all the works in such a manner that there is no adverse impact on the natural surroundings and environment. You shall follow the Environmental norms of ABL.

Regd Office S No 861 Ashoka House Ashoka Marg Vadala, Nashik 422 011 Maharashtra India Tel + 91 253 3011705  
 Fax +91 253 2236704 www.ashokabuildcon.com  
 CIN L45200MH1993PLC071970 Page - 3 - of 5



Handwritten initials/signature.





23. Royalties and Taxes - Your rates are inclusive of all taxes, duties, and insurances. Royalties for soil, aggregate and murum/GSB will be borne by us. You have to submit royalty paid challans for getting its reimbursement from our client M/s Jadcherla Expressway Pvt. Ltd. (JEPL) and the same shall be reimbursed you to the extent it is received from JEPL.
24. Labour Cess - Labour cess will not be borne by you.
25. Change in Law or Taxes - Any changes in any application laws, Taxes, Royalties during the contract period which affects the quoted cost. The Contract price shall be suitably increased by the client so as to place the contractor in the same financial position as he was at the time of bidding of the contract. The threshold for such change to be effected shall be 20 Lac rupees and it shall be reimbursed to the extent it is received from JEPL.
26. Payment - The Contractor shall submit to the Engineer monthly statements of the actually executed work value of the work executed, less the cumulative amount certified previously and, applicable statutory deductions, outstanding advances, approved request for inspections (RFI) for the work done during the month, applicable rates. The total payment shall remain fixed as per the lump sum price agreed in the Contract. The Engineer shall ensure payment of lump sum price only on completion of the whole of the works under the Contract.
27. Advance Payment. The running payments as an advance on the bills as prepared above at the 75% advance payment shall be made within 7 days upon receipt of the same from JEPL after the preliminary checking. The preliminary check shall be done within 7 days from the date of submission of the bill. The balance payment shall be made after 15 days from certification of the bill by the Employer upon receipt of the same from JEPL after deducting a specified percentage. On completion of the work or on earlier termination of this Agreement the final measurements of the work shall be submitted along with the bill by Contractor account shall be adjusted accordingly.
28. Escalation on Bitumen: The base price of Bitumen ex IOCL, Mumbai and IOCL, Koyali as on 16<sup>th</sup> May 2017 is as under:
- Bitumen Grade VG-30 Rs.(Bulk) 25,176/- per MT Ex Mumbai IOCL Refinery  
 Bitumen Grade VG-40 Rs. (Bulk) 25,776/-per MT Ex Koyali Gujarat IOCL Refinery  
 Bitumen Grade VG-30 Rs.(Bulk) 25,576/-per MT Ex Chennai IOCL Refinery  
 Bitumen Grade VG-40 Rs. (Bulk) 26,076/-per MT Ex Chennai IOCL Refinery
- Escalation on Bitumen rate shall be paid on the above mentioned base price of Bitumen  
 Escalation shall not be paid on any other material.
29. The Engineer shall ascertain and determine by measurement the value of the work in accordance with the Contract. The Engineer shall exclude any item in a previous certificate or reduce the proportion of any item previously certified in the light of later information.
30. All payment made against R.A Bill are provisional and shall be treated as advance against Final Bill



*[Handwritten signature]*  
*[Handwritten signature]*

Form EXP - 4.2(b): Specific Construction  
Experience in Key Activities

**Key Activity No. (5)**

- b) Design and Construction of 8 Nos. of toll gates including complete Architectural, Structural, Mechanical, Electrical, Plumbing and Fire Fighting (ASMEP&F) works.

Sub Contractor 4 – Ascent Engineers & Pvt Ltd  
Project 1







**Form EXP – 4.2 (b)**  
**Specific Construction Experience in Key Activities**

Date: 09/12/2021

Bidder's Legal Name: JV of STRABAG Infrastructure & Safety Solutions GmbH and STRABAG AG  
Subcontractor Party Legal Name: ASCENT ENGINEERS & INFRASTRUCTURES INDIA PRIVATE LIMITED

IFB No.: MMRDA/ENG1/0002561

Page 1 of 2 pages

**Key Activity No.(5)**

a) Design and Construction of 8 Nos. of toll gates including complete Architectural, Structural, Mechanical, Electrical, Plumbing and Fire Fighting (ASMEP&F) works.

Item	Information		
Contract Identification	Construction of Toll Plaza ( 6+6 Lanes) in western transport corridor at Tumkur-Haveri Section of NH 4, Package 4 & 5		
Award Date	August -2010		
Completion Date	July -2012		
Role in Contract <i>[check the appropriate box]</i>	<b>Prime Contractor</b>		Management Contractor
	Single entity	JV member	
Total Contract Amount	Rs. 1051 Lakhs		\$2,265,086/-
	Description of the Works undertaken for demonstration of the similarity of the key activity		
Employer's Name:	M/s. Gammon India Limited		
Address:	Gammon House, Veer Savakar Marg, P.O Box No. 9129, Prabhadevi, Mumbai - 400 025		
Telephone/Fax Number:	+91 -22-2430 0221		
E-mail:	gammon@gammonindia.com		

Attached is a true copy of the completion certificate or other similar document(s) for the contract/project issued by the client.





Contd...

Project Consist of following subsystems

Sub Systems	Compliances	Details
Design	Yes	
Construction	Yes	
Architectural	Yes	
Structural	Yes	
Mechanical	Yes	
Electrical	Yes	
Plumbing	Yes	
Fire Fighting	Yes	
No of Lanes	12	

For ASCENT ENGINEERS & INFRASTRUCTURES III PVT. LTD.

Managing Director



ASCENT ENGINEERS & INFRASTRUCTURES INDIA PRIVATE LIMITED CIN No. U45400TN2012PTC086132  
 No. 12, 46th Street, Ashok Nagar, Chennai - 600 083 Tel: +91 44-4211 9330, 4211 9331, 4211 9332  
 E-mail: info@ascentengineer.com Web: www.ascentengineer.com



Form EXP - 4.2(b): Specific Construction  
Experience in Key Activities

**Key Activity No. (5)**

- b) Design and Construction of 8 Nos. of toll gates including complete Architectural, Structural, Mechanical, Electrical, Plumbing and Fire Fighting (ASMEP&F) works.

Sub Contractor 4 – Ascent Engineers & Pvt Ltd

Project 1

True copies of Completion Certificate





**COMPLETION CERTIFICATE**

This is to certify that M/S. Ascent Engineers & Infrastructures India Pvt Ltd., having its registered office at No.12, 46<sup>th</sup> Street, 9<sup>th</sup> Avenue, Ashok Nagar, Chennai - 600 083, have completed the contract of Construction Toll Plaza (6+6 lanes) at in Western Transport Corridor at **Tumkur – Haveri Section** of NH4, Package 4 & 5 at **TWO Locations** KM 237+625 and at KM 4+650

**Each work consists of the following Major items :**

- Toll Plaza -consisting of toll booths, space frame, canopy, roofing etc.,
- Civil works - consisting of island, bull nosing, foundations, crash barriers etc.,
- Rest room, Maintenance Room, Toilet with septic tank, electrical cum panel room, cash loading room.
- Admin block, Highway Patrol, Server Room, Pantry & Change room ( Container )
- UG Sump, water tank, bore well , sanitary & plumbing works
- Cantilever signage, informatory signage, cautionary & hazard signs, etc.
- Compound wall with fencing and gates.
- RCC Tunnel connecting booths to the Admin block.
- Electrification , bay lights, high mast, street light, DG etc.,
- Semi-automatic toll system comprising of boom barriers, overhead light signals, lane signals switches, UPS etc.,

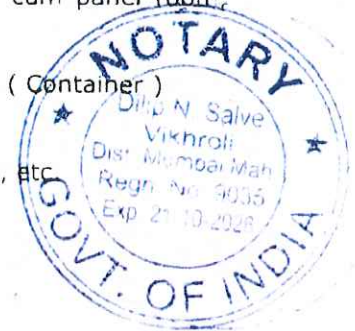

The work was executed including preparation of all working drawings for Plaza. M/S. Ascent Engineers & Infrastructures India Pvt Ltd., is a professionally managed and organized contractor with high performance in quality, safety and timely completion the project.

M/S. Ascent Engineers & Infrastructures India Pvt Ltd, have completed the work satisfactorily within the stipulated period from August 2010 to July 2012. The completion cost of the work is RS. 10.51 Cores. ( Rupees Ten Cores and fifty one lakhs only). The work details as enclosed.



**For Gammon India Limited**

*[Handwritten signature]*

**Authorized Signature**

**GAMMON INDIA LIMITED**

An ISO 9001 Company

**TRUE COPY**

*[Handwritten signature]*  
**Dilip N. Salve**  
ADVOCATE & NOTARY

218 9120 Manes CHS Kanna Nagar Nag.

No. 2, 1st Floor, ...

83





Form EXP - 4.2(b): Specific Construction  
Experience in Key Activities

**Key Activity No. (5)**

- b) Design and Construction of 8 Nos. of toll gates including complete Architectural, Structural, Mechanical, Electrical, Plumbing and Fire Fighting (ASMEP&F) works.

Sub Contractor 4 – Ascent Engineers & Pvt Ltd  
Project 2









Contd...

Project Consist of following subsystems

Sub Systems	Compliances	Details
Design	Yes	
Construction	Yes	
Architectural	Yes	
Structural	Yes	
Mechanical	Yes	
Electrical	Yes	
Plumbing	Yes	
Fire Fighting	Yes	
No of Lanes	12	

For ASCENT ENGINEERS &  
INFRASTRUCTURES (I) PVT. LTD.

*[Signature]*  
Managing Director



Form EXP - 4.2(b): Specific Construction  
Experience in Key Activities

**Key Activity No. (5)**

- b) Design and Construction of 8 Nos. of toll gates including complete Architectural, Structural, Mechanical, Electrical, Plumbing and Fire Fighting (ASMEP&F) works.

Sub Contractor 4 – Ascent Engineers & Pvt Ltd

Project 2

True copies of Completion Certificate







GMR Infrastructure Limited  
EPC Division

**Completion Certificate**



Project Office:  
D. No.: 333, Sai Nilaya,  
1st Cross, Basaveshwara Badavane,  
College Road,  
Hospet - 583 201,  
Bellary (D) Karnataka  
W www.gmrgroup.in

1. Name of Employer : GMR Infrastructure Ltd.
2. Name of work : **Construction of Toll plaza, Control Bldg.,( Civil Works) and Canopy @ Design KM:280.470 at the Hungund – Hospet section of NH-13 in the state of Karnataka.**
3. Agreement No. : GIL-EPC/R003/C&C11-12/011
4. Name of Contractor : M/s.Ascent Engineers
5. Work order value : 3,07,31,480/-
6. Value at completion : 2,61,12,579/-
7. Date of Work Order : 30.09.2011
8. Time for completion : 5-months from Date of WO [29.02.2012]
9. Actual Date of Completion : June 2012



*Certify that*

- a. *Work has been carried out as per standard specification and completed successfully.*
- b. *Certified that there is no recovery outstanding against the contractor.*

*DOs - FYE  
→  
2011/11 - original file  
copy*

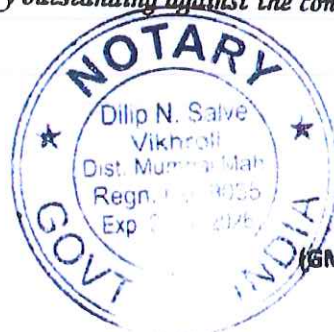

Project Manager  
(GMR Infrastructure Ltd.)



TRUE COPY

*[Handwritten signature]*  
11/12/11

Dilip N. Salve  
ADVOCATE & NOTARY  
9320, Mar 15 CHS, Kannamwar Nagar  
2, V. K. S. E. M. H. S. Road, 4th 083

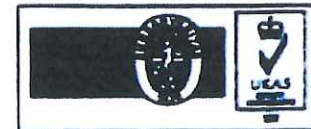

Corporate Office:  
IBC Knowledge Park, Phase 2,  
7<sup>th</sup> Block, 4<sup>th</sup> Floor, 4<sup>th</sup>,  
Bannerghatta Road, Bangalore 560 075  
Registered Office:  
Shop-house, 25<sup>th</sup>, First Floor,  
Museum Road, Bangalore 560 025

Form EXP - 4.2(b): Specific Construction  
Experience in Key Activities

**Key Activity No. (5)**

- b) Design and Construction of 8 Nos. of toll gates including complete Architectural, Structural, Mechanical, Electrical, Plumbing and Fire Fighting (ASMEP&F) works.

Sub Contractor 4 – Ascent Engineers & Pvt Ltd  
Project 3







Form EXP – 4.2 (b)  
Specific Construction Experience in Key Activities

Date: 09/12/2021

Bidder's Legal Name: JV of STRABAG Infrastructure &amp; Safety Solutions GmbH and STRABAG AG

Subcontractor Party Legal Name: ASCENT ENGINEERS &amp; INFRASTRUCTURES INDIA PRIVATE LIMITED

IFB No.: MMRDA/ENG1/0002561

Page 1 of 2 pages

## Key Activity No.(5)

a) Design and Construction of 8 Nos. of toll gates including complete Architectural, Structural, Mechanical, Electrical, Plumbing and Fire Fighting (ASMEP&F) works.

Item	Information		
Contract Identification	Civil and Electrical for Implementation of Electronic Toll Collection(ETC) on Guabari Toll Plaza 1km 243+000 of NH-31C) in the state of West Bengal		
Award Date	15-10-2019		
Completion Date	26-02-2020		
Role in Contract <i>[check the appropriate box]</i>	Prime Contractor		Management Contractor
	Single entity	JV member	
Total Contract Amount	Rs.538.45 Lakhs	\$753271	
Description of the Works undertaken for demonstration of the similarity of the key activity	Construction Civil Electrical works at Guabari Toll Plaza		
Employer's Name:	NATIONAL HIGHWAYS AUTHORITY OF INDIA		
Address:	Guabari Toll Plaza 1km 243+000 of NH-31C) in the state of West Bengal		
Telephone/Fax Number:	0353 2540565,		
E-mail:	sil@nhal.org, piusiliguri@gmail.com		

Attached is a true copy of the completion certificate or other similar document(s) for the contract/project issued by the client.





Project Consist of following subsystems

Sub Systems	Compliances	Details
Design	Yes	
Construction	Yes	
Architectural	Yes	
Structural	Yes	
Mechanical	Yes	
Electrical	Yes	
Plumbing	Yes	
Fire Fighting	Yes	
No of Lanes	8	

For ASCENT ENGINEERS & INFRASTRUCTURES (I) PVT. LTD.

*[Handwritten signature]*





Form EXP - 4.2(b): Specific Construction  
Experience in Key Activities

**Key Activity No. (5)**

- b) Design and Construction of 8 Nos. of toll gates including complete Architectural, Structural, Mechanical, Electrical, Plumbing and Fire Fighting (ASMEP&F) works.

Sub Contractor 4 – Ascent Engineers & Pvt Ltd

Project 3

True copies of Completion Certificate





भारतमाला  
समृद्धि के पथ पर प्रगति  
**BHARATMALA**  
ROAD TO PROSPERITY

# भारतीय राष्ट्रीय राजमार्ग प्राधिकरण

(सड़क परिवहन और राजमार्ग मंत्रालय, भारत सरकार)

## National Highways Authority of India

(Ministry of Road Transport and Highways Govt. of India)

PROJECT IMPLEMENTATION UNIT (PIU) - JALPAIGURI

Sevoke Road, Jyotinagar, Near Don Bosco School, Siliguri - 734001 (W.B.)

Tel : 0353-2540565, e-mail : sil@nha.org, piusiliguri@gmail.com



संदर्भ / Ref. No.

SLG/130182/2019-20/ETC-Guabari/Ascent/150

दिनांक / Dated 06.2020

### COMPLETION CERTIFICATE

1	Name of Work	Civil and Electrical works for implementation of Electronic Toll Collection (ETC) on Guabari Toll Plaza (km 243+000 of NH-31C) in the state of West Bengal
2	Name of Contractor	M/s Ascent Engineers & Infrastructures India Private Ltd. No.12, 46 <sup>th</sup> Street, 9 <sup>th</sup> Avenue, Ashok Nagar, Chennai-600083
3	Letter of acceptance (LoA) issued to be contractor	NHA, RO Kolkata letter No NHA/RO-KOL/001/2019/3(A)-14/ETC/2050 dated 04.10.2019
4	Date of Agreement	15.10.2019
5	Date of Commencement	25.10.2019
6	Contract Price	Rs.4,80,65,937/-
7	Stipulated date of completion	22.01.2020
8	Actual date of completion	26.02.2020 (Including EOT of 36 days)
9	Defect liability period	12 months from actual completion date
10	Value of work executed during contract including variations	Rs 5,38,45,351/-

The certificate is being issued on the request of M/s Ascent Engineers & Infrastructures India Private Ltd. vide his letter No. AEIPL/NHA/GTP/037/20-21 dated 16.05.2020



(P. Dasgupta)  
Project Director

Encls: As Above

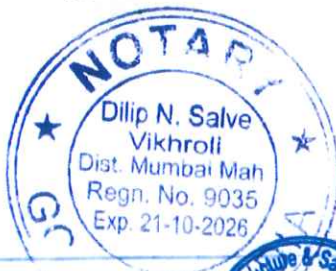

Raju Kumar

TRUE COPY

Dilip N. Salve  
ADVOCATE & NOTARY  
238/9320, Manjeer CHS, Kannamwar Nagar  
No 2 Viji, Siliguri, West Bengal - 734003





Form EXP - 4.2(b): Specific Construction  
Experience in Key Activities

**Key Activity No. (5)**

- b) Design and Construction of 8 Nos. of toll gates including complete Architectural, Structural, Mechanical, Electrical, Plumbing and Fire Fighting (ASMEP&F) works.

Sub Contractor 4 – Ascent Engineers & Pvt Ltd  
Project 4





Form EXP – 4.2 (b)  
Specific Construction Experience in Key Activities

Date: 09/12/2021

Bidder's Legal Name: JV of STRABAG Infrastructure & Safety Solutions GmbH and STRABAG AG  
Subcontractor Party Legal Name: ASCENT ENGINEERS & INFRASTRUCTURES INDIA PRIVATE LIMITED

IFB No. MMRDA/ENG1/0002561  
Page 1 of 2 pages

Key Activity No.(5)

a) Design and Construction of **8 Nos. of toll gates** including complete Architectural, Structural, Mechanical, Electrical, Plumbing and Fire Fighting (ASMEP&F) works.

Item	Information		
Contract Identification	Civil & Electrical works Implementation of Electronic Toll Collection(ETC) on Surjapur Toll Plaza(KM 451.000 NH.31) in the state of West Bengal , NIT No. 03/2014-15(ETC on Surjapur Toll Plaza)		
Award Date	07-04-2015		
Completion Date	10-02-2016		
Role in Contract (check the appropriate box)	Prime Contractor		Management Contractor
	Single entity	JV member	
Total Contract Amount	398.87 lakhs		\$640376
Description of the Works undertaken for demonstration of the similarity of the key activity	Civil & Electrical Works at Surjapur Toll Plaza		
Employer's Name:	NATIONAL HIGHWAYS AUTHORITY OF INDIA		
Address:	Surjapur Toll Plaza(KM 451.000 NH.31) in the state of West Bengal		
Telephone/Fax Number	0353-2540565		
E-mail:	sil@nhai.org, plusiliguri@gmail.com		

Attached is a true copy of the completion certificate or other similar document(s) for the contract/project issued by the client.







Contd

Project Consist of following subsystems

Sub Systems	Compliances	Details
Design	Yes	
Construction	Yes	
Architectural	Yes	
Structural	Yes	
Mechanical	Yes	
Electrical	Yes	
Plumbing	Yes	
Fire Fighting	Yes	
No of Lanes	8	

For ASCENT ENGINEERS &  
INFRASTRUCTURES (II) PVT. LTD.

Managing Director



ASCENT ENGINEERS & INFRASTRUCTURES INDIA PRIVATE LIMITED. CIN No. U45400TN2012PTC086132  
No 12, 46th Street, 9th Avenue, Ashok Nagar, Chennai - 600 083. Tel: +91-44-4211 9330, 4211 9331, 4211 9332  
E-mail: ascent@ascentengineers.com, Web: www.ascentengineer.com



Form EXP - 4.2(b): Specific Construction  
Experience in Key Activities

**Key Activity No. (5)**

b) Design and Construction of 8 Nos. of toll gates including complete Architectural, Structural, Mechanical, Electrical, Plumbing and Fire Fighting (ASMEP&F) works.

Sub Contractor 4 – Ascent Engineers & Pvt Ltd

Project 4

True copies of Completion Certificate







भारतमाला  
समृद्धि के रास्ते पर आगे बढ़ना  
**BHARATMALA**  
ROAD TO PROSPERITY

# भारतीय राष्ट्रीय राजमार्ग प्राधिकरण

(सड़क परिवहन और राजमार्ग विभाग, भारत सरकार)

## National Highways Authority of India

(Ministry of Road Transport and Highways, Govt. of India)

PROJECT IMPLEMENTATION UNIT (PIU) - JALPAIGUR

Sevoke Road, Jyotinagar Near Don Bosco School, Siliguri - 734001 (W.B.)

Tel : 0353-2540665 e-mail sil@nhai.org, piujaliguri@gmail.com



संदर्भ / Ref. No

SLG/130142/2015-16/ETC on Surjapur Toll Plaza | 768

दिनांक / Dated

28.02.2020

### Completion Certificate

1. Name of Work	Civil & Electrical works for implementation of Electronic Toll Collection (ETC) on Surjapur Toll Plaza (km. 451.000 of NH-31) in the State of West Bengal, NIT No. 05/2014-15 (ETC on Surjapur Toll Plaza).
2. Name of Contractor	M/s Ascent Engineers & Infrastructures India Private Ltd., No. 12, 46th Street, 9th Avenue, Ashok Nagar, Chennai (Tamilnadu)
3. Name of the Engineer	M/s Data Technosys (Engineers) Pvt. Ltd.
4. Letter of Acceptance (LOA) issued to the Contractor	SLG/130142/2015-16/ETC on Surjapur Toll Plaza/40 dated 07.04.2015
5. Date of Agreement	06.05.2015
6. Estimated Cost	Rs. 3,56,71,458/-
7. Contract Price	Rs. 3,43,87,285/-
8. Date of commencement	20.05.2015
9. Stipulated date of completion	19.08.2015 (original scope)
10. Actual date of completion	10.02.2016 (including Variation work)
11. Defect Liability Period	09.02.2017 (12 months calculated from actual date of completion)
12. Final contract value	Rs. 3,98,87,050/-

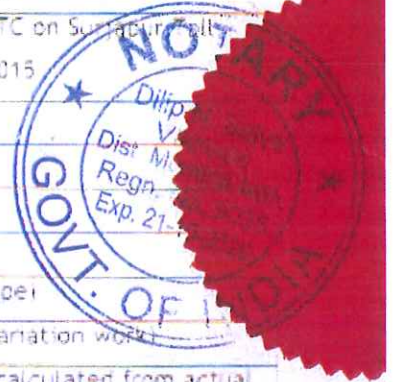

This certificate is being issued on the request of M/s Ascent Engineers & Infrastructures India Private Ltd. vide his letter no. AEIPL/NHA/STP/037/2019-20 dated 27.02.2020.



*(Signature)*  
28.02.2020  
(Pradyut Dasgupta)  
Project Director

**TRUE COPY**



*(Signature)*  
**Dilip N. Salve**  
ADVOCATE & NOTARY  
238/9320, Manar CHS, Kannanwar Nagar  
No. 2, Vikhrol (E), Mumbai - 400 083

